



AQUATIC SYSTEMS EUROPE

CATALOG | **2020** 





Memories Made. **FOR LIFE.**

Sparkling-clean pool and spa water invites a healthy, active lifestyle. Pentair's solutions are engineered to filter, clean and sanitize water to its purest state, while automation equipment makes it all easy to control from anywhere so that you can truly enjoy your pool and spa.

SUMMARY

SWIMMING POOL PUMPS

Single speed, variable speed, flow control.....	10
--	----

SWIMMING POOL FILTERS

Sand, cartridge, D.E.....	36
---------------------------	----

AUTOMATION & REGULATION

Control & automation systems.....	56
-----------------------------------	----

WATER TREATMENT

Salt chlorinator, dosing & measuring, chlorine feeder.....	70
--	----

SWIMMING POOL CLEANERS

Suction-side, pressure-side and electric.....	76
---	----

SWIMMING POOL HEATERING

Heat pump & gas heater.....	84
-----------------------------	----

UNDER WATER LIGHTS

Lights, niches, controllers and accessories.....	92
--	----

WATER FEATURES

Water features & waterfalls.....	102
----------------------------------	-----

WHITE GOODS

Main drain, deckbox, vacuum plate, wall fitting, eyeball inlet.....	108
--	-----

OTHER

Filter valves, filter cartridges, pump union kits, pump replacement baskets.....	112
---	-----

GENERAL TERMS & CONDITION - WARRANTY

General terms & conditions - Warranty.....	116
--	-----

WHY TRADEGRADE?

BECOME A PIP (PARTNERS INCENTIVE PROGRAM) MEMBER AND BENEFIT FROM MULTIPLE ADVANTAGES FROM THE PROFESSIONAL RANGE: TRADEGRADE

ENJOY SELLING ADVANTAGES THAT STRENGTHEN YOUR BUSINESS

TradeGrade products give your business exclusive tools and advantages that easily win against simple discount price competition to boost your profitability while you build better customer relationships.

Customers get the peace of mind that comes with a professional's unmatched technical expertise, which helps ensure accurate equipment selection, setup and servicing.



PROTECTION FOR YOUR BUSINESS

TradeGrade was developed to support your business model and potential for growth.



A VISION FOR THE FUTURE

More freedom to safeguard a sustainable business model aligned for success, now and for years to come.



SAFETY

Peace of mind when equipment is correctly sized, purchased from and installed by a professional.



MORE SELLING POWER

Exclusive tools and lead generation activities that drive business to your door.



LONGER WARRANTIES

Extended warranty on products purchased from and installed by a pool professional.*



MORE ATTRACTIVE REBATES

Real savings bring customers through your door.



LARGER PIP REWARDS

Earn more on every sale. Rewards can be redeemed for prepaid VISA® Cards or a fantastic Path of Paradise Trip.

*Automatic pool cleaners are not required to be professionally installed.

The enhanced TradeGrade policy was designed around three key principles:

PROTECT. EMPOWER. GROW.

WE'VE GOT YOUR BACK.
ALWAYS HAVE.
ALWAYS WILL.



THE APP THAT CHANGES YOUR DAILY BUSINESS! PIPSCANNER

PIP Scanner was designed to enhance the selling and servicing of Pentair's line of products while also simplifying pool professional's daily activities.

In one scan, go to:

- ◆ Co-branded Warranty Certificate*.
- ◆ Warranty extension*.
- ◆ Technical Literature.
- ◆ PIP Cash Rewards.
- ◆ Sales tools.
- ◆ Videos & tutorials..

*available only on TradeGrade products.



Scan
the codes
in the catalog



Download
PIPSCANNER



CATEGORY
WINNER
SMART POOL



POOL
INNOVATIONS
TROPHIES

THE NEW PENTAIR

Pentair is a leading global water treatment company, and is now a pure play water company with a comprehensive range of smart, sustainable water solutions for homes, businesses, industry and communities. Indeed, we have separated from our electrical usiness, which is now called nVent Electric plc ("nVent"), a new independent, publicly traded company, effective April 30, 2018. This new structure allows each business to provide dedicated, best-in-class service for customers, and allows Pentair to further build upon its reputation for excellence in water solutions.

At Pentair, we believe the health of our world depends on reliable access to clean water and our industry-leading smart water solutions enable people, business and industry to access clean, safe water, reduce water consumption, and recover and reuse it.



PENTAIR AQUATIC SYSTEMS

Pentair is an industry leader in designing advanced pool and spa products and technologies that save energy, maintenance time and conserves water within your home. Our smart innovations lead the industry in variable speed pumps, cleaners, automation, sanitization, heating and pool lighting so that you can enjoy your backyard oasis.

Sparkling-clean pool and spa water invites a healthy, active lifestyle. Pentair's solutions are engineered to filter, clean and sanitize water to its purest state, while automation equipment makes it all easy to control from anywhere so that you can truly enjoy your pool and spa.

PENTAIR FACTS

130 locations in 34 countries
Founded in 1966
10 000 employees

OUR "GLOCAL" APPROACH :

WE ARE A GLOBAL COMPANY...

Present on 5 continents.

Manufacturing practices are strongly embedded in our values : driving day-to-day activities with a focus on continuous improvement to satisfy customers' needs.

... WITH A LOCAL MANUFACTURING

In today's uncertain and globalized economical atmosphere, products manufactured locally become particularly valuable. Indeed, they inspire trust by their belonging to the traditional European knowledge and quality-focused manufacturing. That's why we, at Pentair, are particularly proud to develop and/or assemble the large majority of our products in our European production sites of Pisa (IT) and Herentals (BE).



Smart, Sustainable Water Solutions. **FOR LIFE.**



HERENTALS (BE) PRODUCTION SITE

Founded in 1977, the 11'000 m² Herentals site focuses on the production of filters and Structural polyglass pressure vessels, as well water softeners. The Herentals team is in permanence focusing on continuous improvement. By using PIMS (Pentair Integrated Management System), employees drive performance improvement concerning safety, cost, quality and delivery every day.



PISA (IT) PRODUCTION SITE

Founded in 1989, Pisa is Pentair's center of excellence for pumps and valves. It is also Pentair's most environmentally friendly facility, with all of its power requirements coming from solar panels!

Since 2010, Pisa plant has a solar roof system, made of 4'110 photovoltaic panels, producing 1200 mWh of energy per year. A complete installation of LED technology (Light Emitting Diode) took place in the Pisa plant in 2017. Since that date, the plant has been utilizing 84 percent less power than previously.



SEBASTIEN GAUTHIER
DIRECTOR EUROPE
 sebastien.gauthier@pentair.com



STÉPHANE LEDRU
SALES DIRECTOR EUROPE
 stephane.ledru@pentair.com



COMMERCIAL ORGANISATION



GIANLUCA INSELVINI
AREA SALES MANAGER FRANCE
 gianluca.inselvini@pentair.com



ROMAIN MATHOUD
AREA SALES DEVELOPER EAST FRANCE
 romain.mathoud@pentair.com



BENJAMIN CAUSSE
AREA SALES DEVELOPER WEST FRANCE
 benjamin.causse@pentair.com



Open position
AREA SALES DEVELOPER FRANCE

FRANCE



MAXIME GUIANVARCH
AREA SALES MANAGER BENELUX, UK & DACH
 maxime.guianvarch@pentair.com



Open position
AREA SALES DEVELOPER BENELUX, UK



Open position
AREA SALES DEVELOPER DACH (DEUTSCHLAND, AUSTRIA & SWITZERLAND)

BENELUX, UK & DACH



MASSIMO FERRARI
AREA SALES MANAGER SOUTH OF EUROPE
 massimo.ferrari@pentair.com



BARBARA RINALDI
INSIDE SALES MANAGER REST OF EUROPE
 barbara.rinaldi@pentair.com

SOUTH OF EUROPE

REST OF EUROPE



PENTAIR RECRUITS!

Marketing Manager, Product Manager (Nice-FR), Engineer (Pisa-IT)
 If you want to apply for one of the open positions,
 please send your application to : careers.pooleurope@pentair.com

CUSTOMER SERVICE



CRISTIANA CASAROSA
CUSTOMER SERVICE MANAGER
LANGUAGES : IT - EN - FR - RUS - GE
cristiana.casarosa@pentair.com
+39 05 07 16 118



ELISA FABBRICIANI
CUSTOMER SERVICE REPRESENTATIVE
LANGUAGES : IT - EN - FR - GE
elisa.fabbriciani@pentair.com
+39 05 07 16 166



ALEXANDRA MURA
CUSTOMER SERVICE REPRESENTATIVE
LANGUAGES : IT - DE - EN - FR - SP
alexandramelanie.mura@pentair.com
+39 05 07 16 169



GLORIA SABO
CUSTOMER SERVICE REPRESENTATIVE
LANGUAGES : IT - EN - FR - GE
gloria.sabo@pentair.com
+39 05 07 16 827

TECHNICAL SUPPORT AND TRAINING



ARNAUD BESSON
TECHNICAL SUPPORT MANAGER FRANCE
arnaud.besson@pentair.com
+33 (0)9 72 54 46 71



GREGORY THEUNIS
TECHNICAL SUPPORT MANAGER REST OF EU
gregory.theunis@pentair.com
+32 14 25 99 11



Open position
TECHNICAL SUPPORT FRANCE



Open position
TECHNICAL SUPPORT FRANCE

MARKETING



MATTHIEU SELVA
MARKETING & PRODUCT MANAGER
marketing.poolemea@pentair.com



KATRIEN VAN LOY
PIP PROGRAM ADMIN
pip.poolemea@pentair.com



Open position
CONTENT MARKETING MANAGER



MEHMET YALCIN
DIGITAL MARKETING SPECIALIST
pipscanner@pentair.com

A TEAM AT YOUR SERVICE !



WHY CHOOSING VARIABLE SPEED ?

◆ FILTRATION QUALITY

At low pump rotation speed, water flows slowly through the filter enabling small debris to be better captured and water chemistry to remain more balanced. At high pump rotation speed, high flow allows for more efficient filter back-washing and suction side cleaning.

◆ LOW NOISE









While rotating slower, the pump is doing much less noise than a single speed pump.

◆ ENERGY SAVING

By adapting speed according to the filtration needs. Low speed is ideal for optimum filtration but it also consumes much less energy. Indeed when flow is reduced by half, energy consumption is cut by 8!

◆ LESS PUMP WEAR AND TEAR

Because it does not operate constantly at full speed, motor temperature remains low thus components longer lasting.

	106 dB
	70 dB
	70 dB
	70 dB
	67 dB
	60 dB
	50 dB
	45 dB
	30 dB

Single speed Pump

INTELLIFLO®

WHY PENTAIR IS THE LEADER?

◆ VARIABLE SPEED PIONEER

Including variable flow technology with the first IntelliFlo VF, launched in 2004.

◆ PROVEN RELIABILITY AND TECHNOLOGY MASTERING

◆ PRESENCE ON THE MARKET FOR 15+ YEARS

More than 1.5 millions installed variable speed pumps that have enabled saving of 11.5 billions of kilowatt hours (kWh) in the world, representing the equivalent annual energy consumption of 1.3 million households.

◆ WIDE RANGE

12 models including 4 IntelliFlo's.

◆ EUROPEAN LARGEST POOL PUMPS INSTALLED BASED

A huge potential of upgrade into variable speed thanks to upgrade kits without the need for modifying the existing plumbing.

◆ POWERED BY SPECIFIC AUTOMATION SYSTEM

The only manufacturer with smart pumps and associated automation systems to get optimum performances and efficiency.

◆ PENTAIR IS THE ONLY MANUFACTURER TO OFFER VARIABLE SPEED AND FLOW CONTROL

WHY FLOW CONTROL WITH INTELLIFLO VSF ?

◆ BY ENSURING A CONSTANT FLOW IN THE SYSTEM, THE INTELLIFLO VSF ENSURES:

- a constant water recirculation and an optimal filtration,
- a maximum heating efficiency,
- an optimized water treatment,
- that water jets, laminars & waterfalls look their best.

◆ EVEN MORE SAVINGS

Traditional variable speed pumps are set to run faster than needed early in the filtration cycle to compensate for flow reduction later as debris accumulate in the filter. The IntelliFlo VSF pump adjusts flow throughout the cycle to minimize energy use.

◆ SET IT AND FORGET IT

IntelliFlo VSF pump maintains its set flow rate by responding to changing conditions. It's like the cruise control of modern cars for your pump.

IntelliFlo®



Up to

90%
of Energy Savings



SWIMMING POOL PUMPS

Single speed, variable speed, variable speed and flow control



OUR MOTORS	12	"5P2R" SERIES	28
SINGLE SPEED		5P2R™, S5P2R™	
VARIABLE SPEED		S5P2R™ VS, S5P2R™ VS2	
VARIABLE SPEED AND FLOW CONTROL			
"WHISPERFLO" SERIES	14	"XF" SERIES	30
WHISPERFLO®		5PXF™	
WHISPERFLO® VS2		INTELLIFLO® 5PXF™ VSF	
INTELLIFLO® WHISPERFLO® VSF		MAX-E-PROXF® VS	
"WHISPERPRO" SERIES	16	ABOVE-GROUND PUMPS	32 & 33
WHISPERPRO S5P5R™		SWIMMEY™	
		FREEFLO™	
"SUPERFLO" SERIES	18	BOOSTER PUMPS	34
SUPERFLO®		BLUEFLO®	
SUPERFLO® VS2		BLUEFLO® LITE	
"SUPERMAX" SERIES	20		
SUPERMAX® S5P1R			
SUPERMAX® VS2			
"ULTRAFLOW" SERIES	22		
ULTRAFLOW®			
ULTRAFLOW® VS			
INTELLIFLO® ULTRAFLOW® VSD2			
"ULTRA-GLAS" SERIES	24		
ULTRA-GLAS® S5P3R			
"5P6R" SERIES	26		
5P6R™ / SW5P6R™			
INTELLIFLO® SW5P6R™ VSD2			





OUR MOTORS

SINGLE SPEED, VARIABLE SPEED, VARIABLE SPEED AND FLOW CONTROL

SINGLE SPEED

	<ul style="list-style-type: none"> ◆ 100% Made by Pentair in our Pisa, Italy plant ◆ Bi-material shaft with Stainless Steel 304 shaft -end ◆ SKF sealed bearings ◆ Thermal Protection (single phase) ◆ IE3 compliant (tri-phase) 	
	<ul style="list-style-type: none"> ◆ Made in Austria by ATB® ◆ Bi-material shaft with Stainless Steel 316 shaft -end (S version) ◆ Sealed bearings ◆ Thermal Protection (single phase) ◆ IE3 compliant (tri-phase) 	

VARIABLE SPEED

VS	<ul style="list-style-type: none"> ◆ 1.5hp permanent magnets motor, made in USA ◆ 3 programmable speed/time + override ◆ Simple and intuitive LED display ◆ Internal timer ◆ 4 digital inputs for external control 	
VS2	<ul style="list-style-type: none"> ◆ Oversized 3hp asynchronous motor derated to 1.5hp to deliver high efficiency even at high speed. ◆ 3 programmable speed/time + override ◆ Simple and intuitive LCD display with Watts, RPM & time info ◆ Real time clock with 24hrs retention ◆ 4 digital inputs for external control (optional communication cable - PN. 353129Z) 	
INTELLIFLO® VSD2	<ul style="list-style-type: none"> ◆ 3hp permanent magnets motor, made in Italy, improved efficiency ◆ 8 programmable speed/time - simplified menus ◆ Rotatable LCD display / optional wall-mounting kit (PN. R356905) ◆ Real time clock with 24hrs retention ◆ RS485 Modbus communication / Optional control cable (PN. R350122) 	

VARIABLE SPEED AND FLOW

INTELLIFLO® VSF	<ul style="list-style-type: none"> ◆ All advantages of IntelliFlo VSD2 with additional Flow Control ◆ Maintain constant flow in the system without any required setting (Pentair patent) ◆ TradeGrade exclusivity, only available on Whisper and XF lines. ◆ RS485 Modbus communication / Optional control cable (PN. R350122) 	
------------------------	--	---

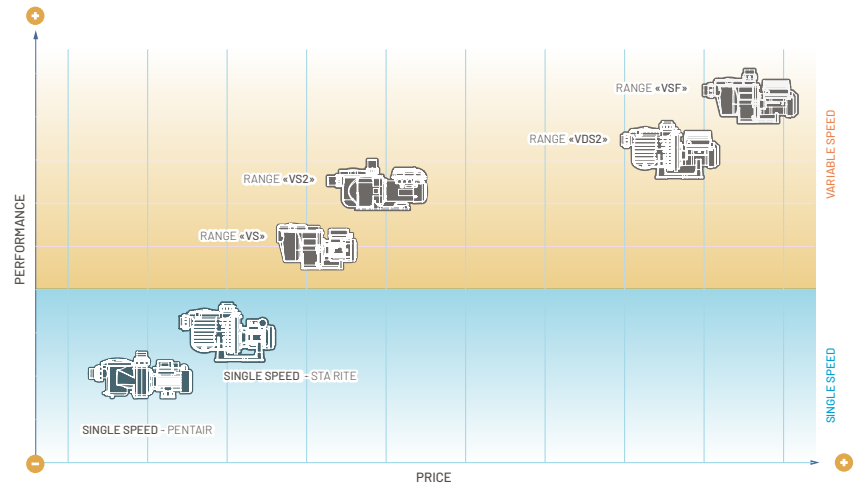

		SINGLE SPEED		VARIABLE SPEED			VARIABLE SPEED AND FLOW
		PENTAIR	STA-RITE™	VS	VS2	IntelliFlo® VSD2	IntelliFlo® VSF
POWER OUTPUT P2	HP	0.5 - 3	0.5 - 3	1.5	1.5	3	3
	kW	0.18 - 2.2	0.37 - 2.2	1.1	1.1	2.2	2.2
Savings*		N/A	N/A	Up to 80%	Up to 80%	Up to 90%	Up to 90%
Decibels (dB)**		67	67	49	47	45	45
RPM		2850	2850	0 - 3450	0 - 3450	450 - 3450	450 - 3450
Technology		Induction asynchronous	Induction asynchronous	Synchronous permanent magnet	High efficiency Induction asynchronous	Synchronous permanent magnet	Synchronous permanent magnet
Priming speed (RPM)		N/A	N/A	2800 Permanent	Min. 1700 Adjustable	Min. 800 Adjustable	Min. 800 Adjustable
Warranty		3 year	3 year	3 year	3 + 1 year (TradeGrade)	3 year	3 + 1 year (TradeGrade)
Price		€	€	€€	€€€	€€€€	€€€€
Automation		On / Off	On / Off	4 dry contacts	4 dry contacts	RS485	RS485
Programmation		N / A	N / A	Speed	Speed	Speed	Speed & Flow
User Interface		N / A	N / A	LED	LCD display	Rotatable LCD display Optional: wall-mounting kit	Rotatable LCD display Optional: wall-mounting kit
Automatisation compatibility		Maestro Soleo	Maestro Soleo	Maestro+Speed FC Soleo VS	Maestro+Speed FC Soleo VS	IntelliPool Maestro+Speed FC Soleo VS	IntelliPool Maestro+Speed FC Soleo VS
IP		IP-X5	IP-X5	IP-X4	IP-X6	IP-X5	IP-X5
Phase		1~ or 3~	1~ or 3~	1~	1~	1~	1~

* Savings based on variable speed pump compared to single-speed pump running all year round, 12 hours per day on a 75m 3 pool. Actual savings may vary based on local rates, pool size, pump run time, pump horse power, pump rpm, plumbing size and length, pump model, service factor and other hydraulic factors.

** 1.5hp single speed pump / 1500 RPM variable speed pump

WHISPERFLO®, WHISPERFLO® VS2, INTELLIFLO® WHISPERFLO® VSF

First-in-class hydraulic performances, modern design for the highest efficiency at low speed with very low energy consumption.



WHISPERFLO®



WHISPERFLO® VS2

TRADEGRADE



INTELLIFLO® WHISPERFLO® VSF

TRADEGRADE



FEATURES

- 1/4 turn opening lid
- Quick self priming
- One-piece pump body

BENEFITS

- ➔ Easy opening and locking
- ➔ Quick and safe start of the pump
- ➔ Super silent

TECHNICAL SPECIFICATIONS

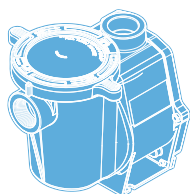

Inlet/Outlet	2" BSP tapped
Ø Unions	50 mm or 63 mm
Unions incl.	VS2 and VSF
Salt resistancy	0,4 %

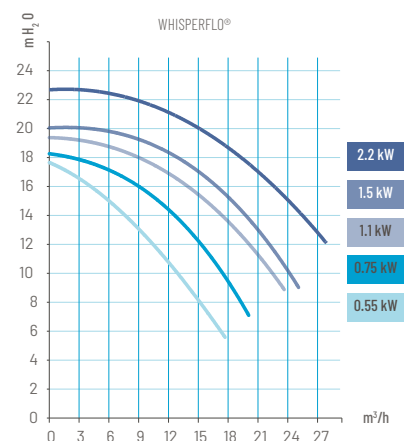
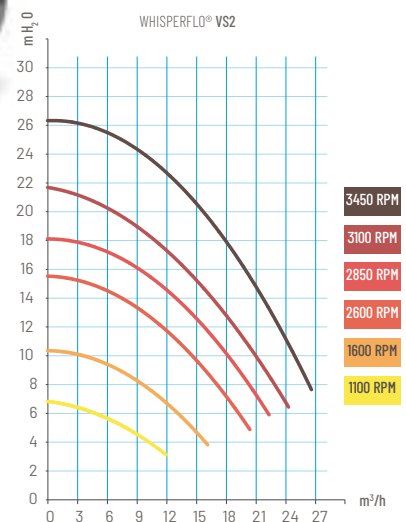
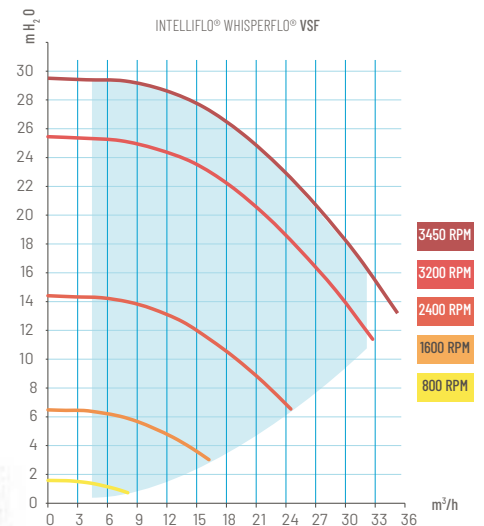

TECHNICAL SPECIFICATIONS & PRICE

Part Number	Speed	m ³ / h @ 8 m	Power output P2		Volt (V)	Phase	Length (mm)	Weight (Kg)	Warranty (year)	PIP Points	List Price (€ VAT excl)
			(kW)	(HP)							
PENTAIR WHISPERFLO® 2											
P-WFL-071	Single	15	0,55	0.75	220-240	1~	542	14,3	3	75	706
P-WFL-073	Single	15	0,55	0.75	380-420	3~	534	12,6	3	75	706
P-WFL-101	Single	19	0,75	1	220-240	1~	542	13,7	3	75	793
P-WFL-103E3 ⁽¹⁾	Single	19	0,75	1	380-420	3~	534	14,3	3	75	820
P-WFL-151	Single	23	1,10	1,5	220-240	1~	562	15,3	3	75	873
P-WFL-153E3 ⁽¹⁾	Single	23	1,10	1,5	380-420	3~	562	22,3	3	75	921
P-WFL-201	Single	24	1,50	2	220-240	1~	562	16,8	3	75	1029
P-WFL-203E3 ⁽¹⁾	Single	24	1,50	2	380-420	3~	562	23,9	3	75	1107
P-WFL-301	Single	32	2,20	3	220-240	1~	593	23,0	3	75	1282
P-WFL-303E3 ⁽¹⁾	Single	32	2,20	3	380-420	3~	593	30,3	3	75	1382
WFL-VS2	Variable	27	1.5	1,65	220-240	1~	560	24,5	3 + 1	150 + 50	1295
WFL-VSF	IntelliFlo®	39	2,20	3	220-240	1~	594	23,0	3 + 1	250 + 100	1881

⁽¹⁾ IE3 compliant

DIMENSIONS

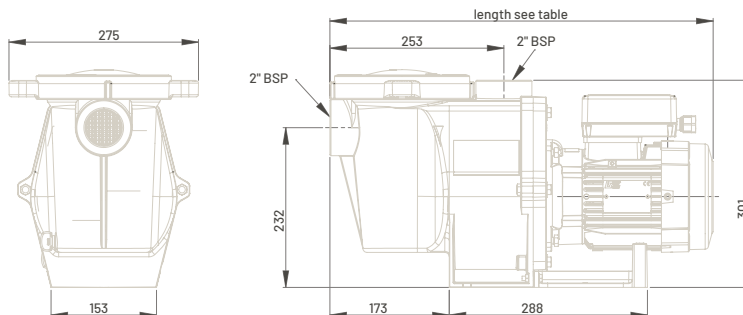

PACKAGING

BOX			PALET			
Length (cm)	Width (cm)	Height (cm)	Length (cm)	Width (cm)	Height (cm)	Pce/Palet
65	33	38	130	100	165	24

WHISPERPRO® S5P5R™

WHISPERPRO® S5P5R™ SERIES

TRADEGRADE

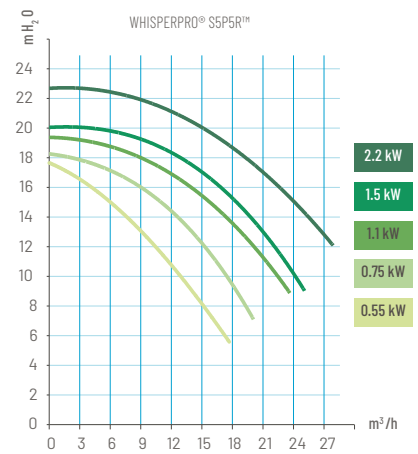

FEATURES

- ¼ turn opening lid
- Quick self priming
- One-piece pump body

BENEFITS

- ➔ Easy opening and locking
- ➔ Quick and safe start of the pump
- ➔ Super silent

TECHNICAL SPECIFICATIONS

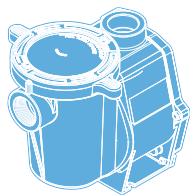

Inlet/Outlet	2" BSP tapped
Ø Unions	50 mm or 63 mm
Unions included	Yes
Salt resistancy	0,4 %

TECHNICAL SPECIFICATIONS & PRICE

Part Number	Speed	m ³ / h @ 8 m	Power output P2 (kW)	(HP)	Volt (V)	Phase	Length (mm)	Weight (Kg)	Warranty (year)	PIP Points	List Price (€ VAT excl)
-------------	-------	--------------------------	----------------------	------	----------	-------	-------------	-------------	-----------------	------------	-------------------------

STA-RITE™ WHISPERPRO®

S5P5RD-1	Single	14,3	0,55	0,75	220-240	1~	562	14,3	3	75 + 25	758
S5P5RD-3	Single	12,6	0,55	0,75	380-420	3~	567	12,6	3	75 + 25	758
S5P5RE-1	Single	13,7	0,75	1	220-240	1~	572	13,7	3	75 + 25	850
S5P5RE-3E3 ⁽¹⁾	Single	14,3	0,75	1	380-420	3~	602	14,3	3	75 + 25	881
S5P5RF-1	Single	15,3	1,10	1,5	220-240	1~	572	15,3	3	75 + 25	937
S5P5RF-3E3 ⁽¹⁾	Single	22,3	1,10	1,5	380-420	3~	602	22,3	3	75 + 25	989
S5P5G-1	Single	16,8	1,50	2	220-240	1~	607	16,8	3	75 + 25	1106
S5P5RG-3E3 ⁽¹⁾	Single	23,9	1,50	2	380-420	3~	642	23,9	3	75 + 25	1189
S5P5RH-1 ¹	Single	25,0	2,2	3	220-240	1~	632	25,0	3	75 + 25	1378
S5P5RH-3E3 ⁽¹⁾	Single	30,3	2,2	3	380-420	3~	647	30,3	3	75 + 25	1483

⁽¹⁾ IE3 compliant

DIMENSIONS

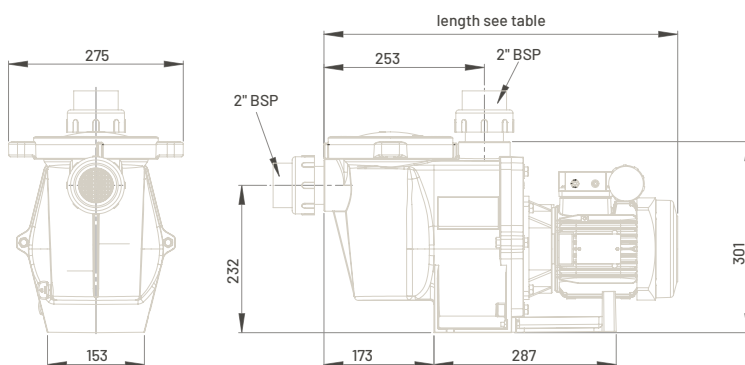

PACKAGING

BOX			PALET			
Length (cm)	Width (cm)	Height (cm)	Length (cm)	Width (cm)	Height (cm)	Pce/Palet
65	33	38	130	100	165	24

SUPERFLO[®], SUPERFLO[®] VS, SUPERFLO[®] VS2

SUPERFLO pumps offer the best price quality ratio.



SUPERFLO[®]



VS2 DISPLAY

SUPERFLO[®] VS2

TRADEGRADE



FEATURES

- XL pre filter basket
- ¼ turn opening lid
- Quick self priming
- One-piece pump body

BENEFITS

- ➔ Longer periods between cleanings
- ➔ Easy opening and locking
- ➔ Quick and safe start of the pump
- ➔ Super silent

TECHNICAL FEATURES

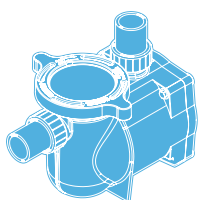

Inlet/Outlet	1.5" BSP tapped
Ø Unions	50 mm
Unions included	VS and VS2
Salt resistancy	0,4 %

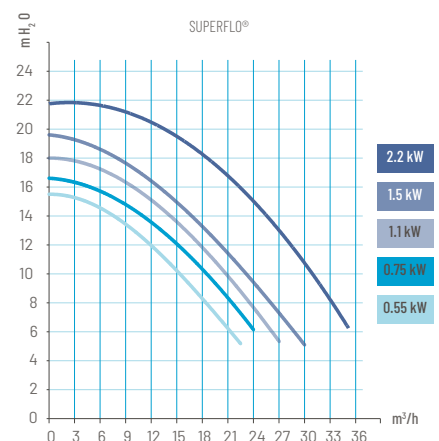
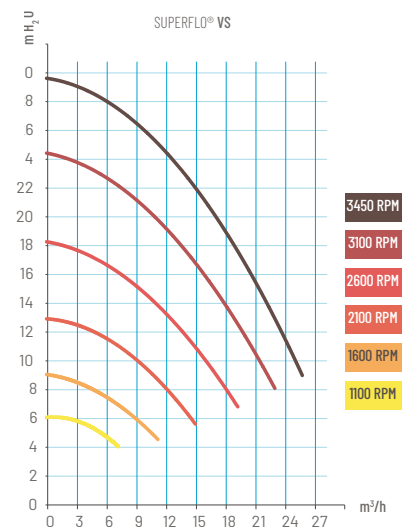
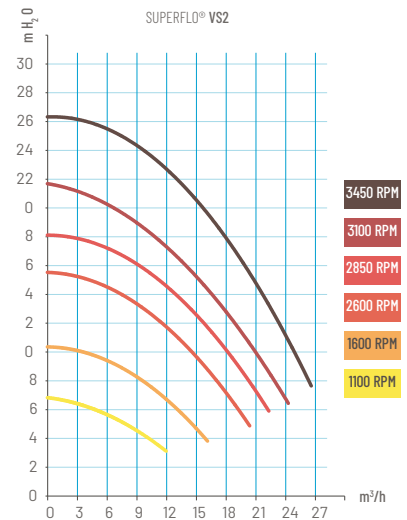

TECHNICAL SPECIFICATIONS & PRICE

Part Number	Speed	m ³ / h @ 8 m	Power output P2		Volt (V)	Phase	Length (mm)	Weight (Kg)	Warranty (year)	PIP Points	List Price (€ VAT excl)
			(kW)	(HP)							
PENTAIR SUPERFLO® 2											
P-SFL-051	Single	15	0,37	0,5	220-240	1~	546	13,8	3	50	431
P-SFL-071	Single	18	0,55	0,75	220-240	1~	546	14,1	3	50	482
P-SFL-073	Single	18	0,55	0,75	380-420	3~	529	12,5	3	50	482
P-SFL-101	Single	21	0,75	1	220-240	1~	577	14,6	3	50	520
P-SFL-103E3 ⁽¹⁾	Single	21	0,75	1	380-420	3~	529	13,9	3	50	547
P-SFL-151	Single	24	1,10	1,5	220-240	1~	577	15,6	3	50	572
P-SFL-153E3 ⁽¹⁾	Single	24	1,10	1,5	380-420	3~	557	22,3	3	50	613
P-SFL-201	Single	26	1,50	2	220-240	1~	557	17,0	3	50	678
P-SFL-203E3 ⁽¹⁾	Single	26	1,50	2	380-420	3~	557	23,9	3	50	741
P-SFL-301	Single	33	2,20	3	220-240	1~	588	23,3	3	50	836
P-SFL-303E3 ⁽¹⁾	Single	33	2,20	3	380-420	3~	588	30,0	3	50	915
SFL-VS2	Variable	26	1,10	1,5	220-240	1~	605	21,6	3+1	150+50	1189

⁽¹⁾ IE3 compliant

DIMENSIONS

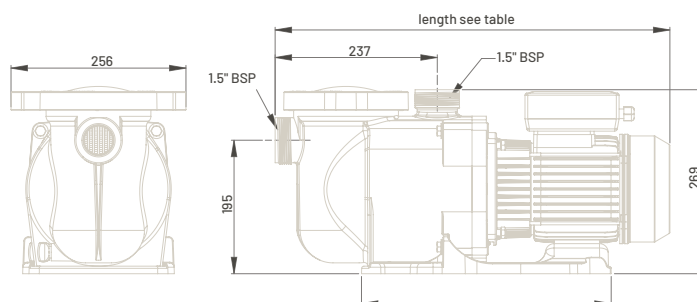

PACKAGING

BOX			PALET			
Length (cm)	Width (cm)	Height (cm)	Length (cm)	Width (cm)	Height (cm)	Pce/Palet
65	33	38	130	100	165	24

SUPERMAX® S5P1R, SUPERMAX® VS2

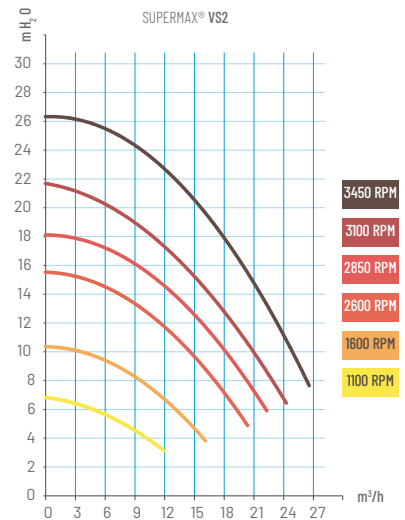

SUPERMAX® S5P1R

TRADEGRADE



SUPERMAX® VS2

TRADEGRADE



FEATURES

- XL pre filter basket
- ¼ turn opening lid
- Quick self priming
- One-piece pump body

BENEFITS

- ➔ Longer periods between cleanings
- ➔ Easy opening and locking
- ➔ Quick and safe start of the pump
- ➔ Super silent

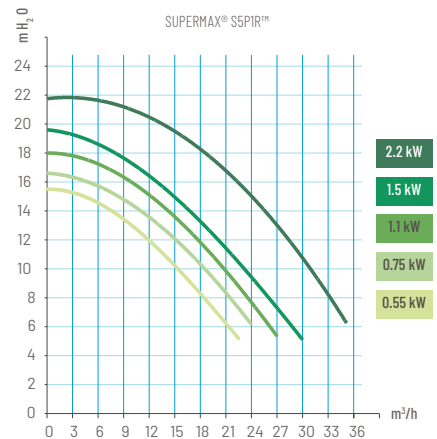

TECHNICAL FEATURES

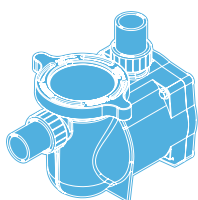

Inlet/Outlet	1.5" BSP tapped
Ø Unions	50 mm
Unions included	SuperMax, VS2
Salt resistancy	0,4 %

TECHNICAL SPECIFICATIONS & PRICE

Part Number	Speed	m ³ / h @ 8 m	Power output P2 (kW) (HP)		Volt (V)	Phase	Length (mm)	Weight (Kg)	Warranty (year)	PIP Points	List Price (€ VAT excl)
STA-RITE™ SUPERMAX®											
S5P1RC-1	Single	15	0,37	0,5	220-240	1~	560	13,8	3	50	481
S5P1RD-1	Single	18	0,55	0,75	220-240	1~	560	14,1	3	50	538
S5P1RD-3	Single	18	0,55	0,75	380-420	3~	565	12,5	3	50	538
S5P1RE-1	Single	21	0,75	1	220-240	1~	570	14,6	3	50	582
S5P1RE-3E3 ⁽¹⁾	Single	21	0,75	1	380-420	3~	600	13,2	3	50	601
S5P1RF-1	Single	24	1,10	1,5	220-240	1~	570	15,6	3	50	640
S5P1RF-3E3 ⁽¹⁾	Single	24	1,10	1,5	380-420	3~	600	15,4	3	50	674
S5P1RG-1	Single	26	1,50	2	220-240	1~	605	17,0	3	50	759
S5P1RG-3E3 ⁽¹⁾	Single	26	1,50	2	380-420	3~	640	17,0	3	50	815
S5P1RH-1	Single	33	2,20	3	220-240	1~	630	23,3	3	50	936
S5P1RH-3E3 ⁽¹⁾	Single	33	2,20	3	380-420	3~	645	21,0	3	50	1007
S5P1R-VS2	Variable	26	1,10	1,5	220-240	1~	605	21,6	3+1	150+50	1268

⁽¹⁾ IE3 compliant

DIMENSIONS

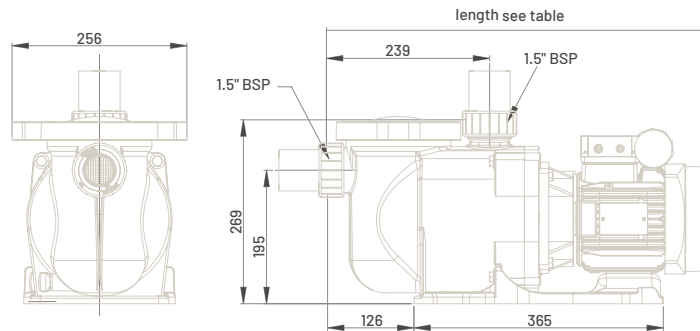

PACKAGING

BOX			PALET			
Length (cm)	Width (cm)	Height (cm)	Length (cm)	Width (cm)	Height (cm)	Pce/Palet
65	33	38	130	100	165	24

ULTRAFLOW®, ULTRAFLOW® VS, INTELLIFLO® ULTRAFLOW® VSD2

Appreciated for its large pre filter and its quick and easy maintenance.



ULTRAFLOW®



ULTRAFLOW® VS



INTELLIFLO® ULTRAFLOW® VSD2



FEATURES

- XL pre filter basket
- Stainless steel locking clamp
- ¼ turn opening lid
- Quick self priming

BENEFITS

- ➔ Longer periods between cleanings
- ➔ Quick maintenance and upgradability into variable speed pump (with kit UFL-CVS)
- ➔ Easy opening and locking
- ➔ Quick and safe start of the pump

TECHNICAL FEATURES

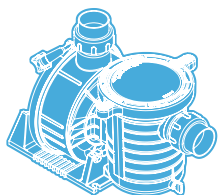

Inlet/Outlet	2" BSP tapped
Ø Unions	50 mm or 63 mm
Unions included	VS and VSD2
Salt resistancy	0,4 %

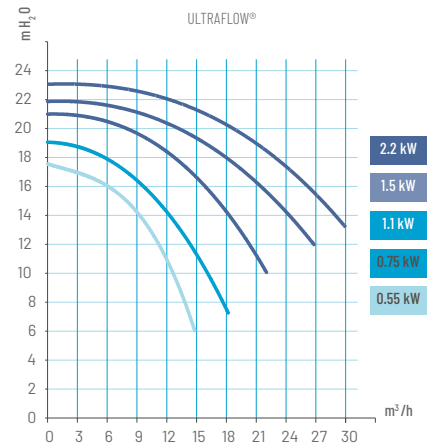
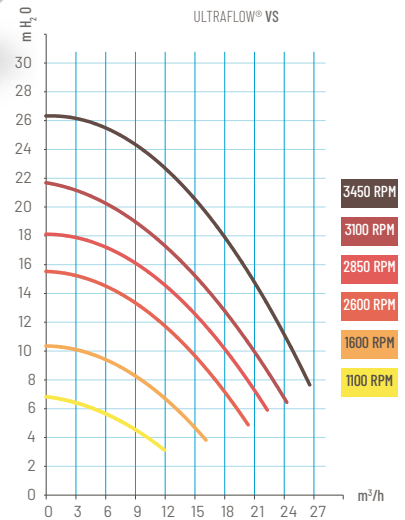
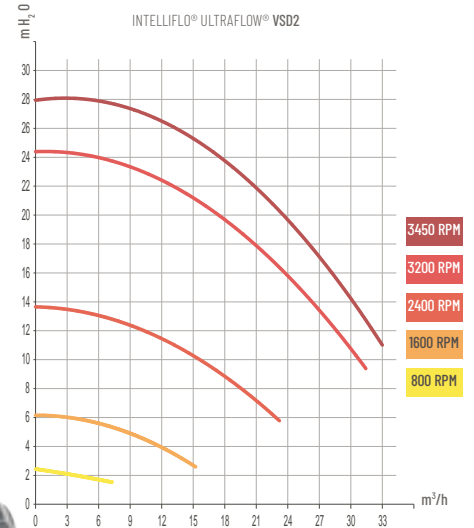

TECHNICAL SPECIFICATIONS & PRICE

Part Number	Speed	m ³ / h @ 8 m	Power output P2		Volt (V)	Phase	Length (mm)	Weight (Kg)	Warranty (year)	PIP Points	List Price (€ VAT excl)
			(kW)	(HP)							
PENTAIR ULTRAFLOW® 2											
P-UFL-071	Single	14	0,55	0,75	220-240	1~	529	14,7	3	50	566
P-UFL-073	Single	14	0,55	0,75	380-420	3~	521	12,0	3	50	566
P-UFL-101	Single	18	0,75	1	220-240	1~	529	14,8	3	50	615
P-UFL-103E3 ⁽¹⁾	Single	18	0,75	1	380-420	3~	521	15,0	3	50	650
P-UFL-151	Single	22	1,10	1,5	220-240	1~	549	16,3	3	50	678
P-UFL-153E3 ⁽¹⁾	Single	22	1,10	1,5	380-420	3~	549	22,7	3	50	728
P-UFL-201	Single	28	1,50	2	220-240	1~	549	17,9	3	50	808
P-UFL-203E3 ⁽¹⁾	Single	28	1,50	2	380-420	3~	549	24,3	3	50	884
P-UFL-301	Single	33	2,20	3	220-240	1~	630	25	3	50	989
P-UFL-303E3 ⁽¹⁾	Single	33	2,20	3	380-420	3~	650	28	3	50	1083
UFL-VS	Variable	22	1,10	1,5	220-240	1~	610	23	3	150	1339
UFL-VSD2	IntelliFlo®	35	2,20	3	220-240	1~	650	22,6	3	250	1907

⁽¹⁾ IE3 compliant

DIMENSIONS

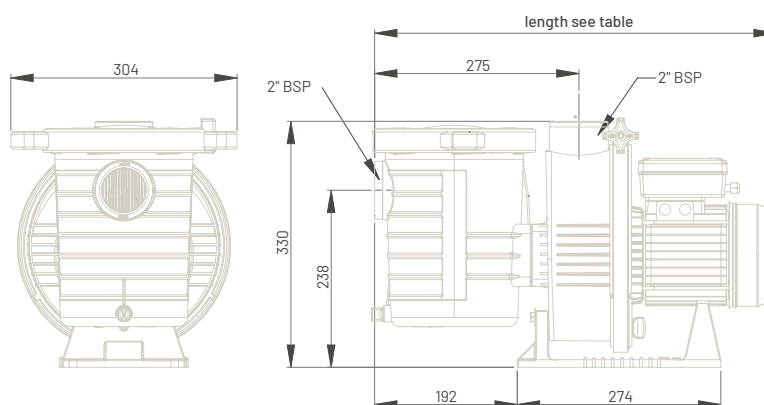

PACKAGING

Part Number	BOX			PALET			
	Length (cm)	Width (cm)	Height (cm)	Length (cm)	Width (cm)	Height (cm)	Pce/Palet
P-UFL... UFL-VS...	65	33	38	130	100	165	24
P-UFL-301 P-UFL-303E3	80	37.5	60	120	80	165	9

ULTRA-GLAS® S5P3R

ULTRA-GLAS® S5P3R

TRADEGRADE

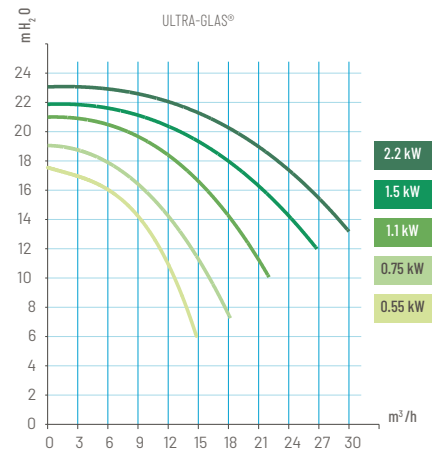

FEATURES

- XL pre filter basket
- Stainless steel locking clamp
- 1/4 turn opening lid
- Quick self priming

BENEFITS

- ➔ Longer periods between cleanings
- ➔ Quick maintenance and upgradability into variable speed pump (with kit UFL-CVS)
- ➔ Easy opening and locking
- ➔ Quick and safe start of the pump

TECHNICAL FEATURES

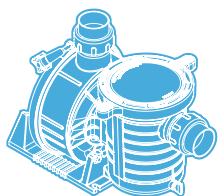

Inlet/Outlet	2" BSP tapped
Ø Unions	50 mm or 63 mm
Unions included	Yes
Salt resistancy	0,4 %

TECHNICAL SPECIFICATIONS & PRICE

Part Number	Speed	m ³ / h @ 8 m	Power output P2 (kW)	(HP)	Volt (V)	Phase	Length (mm)	Weight (Kg)	Warranty (year)	PIP Points	List Price (€ VAT excl)
-------------	-------	-----------------------------	-------------------------	------	-------------	-------	----------------	----------------	--------------------	------------	----------------------------

STA-RITE™ ULTRA-GLAS®

S5P3RD-1	Single	14	0,55	0,75	220-240	1~	549	14,7	3	50	617
S5P3RD-3	Single	14	0,55	0,75	380-420	3~	554	12,0	3	50	617
S5P3RE-1	Single	18	0,75	1	220-240	1~	559	14,8	3	50	671
S5P3RE-3E3 ⁽¹⁾	Single	18	0,75	1	380-420	3~	589	15,0	3	50	698
S5P3RF-1	Single	22	1,10	1,5	220-240	1~	559	16,3	3	50	740
S5P3RF-3E3 ⁽¹⁾	Single	22	1,10	1,5	380-420	3~	589	22,7	3	50	781
S5P3RG-1	Single	28	1,50	2	220-240	1~	594	17,9	3	50	881
S5P3RG-3E3 ⁽¹⁾	Single	28	1,50	2	380-420	3~	629	24,3	3	50	950
S5P3RH-1	Single	33	2,20	3	220-240	1~	619	25	3	50	1077
S5P3RH-3E3 ⁽¹⁾	Single	33	2,20	3	380-420	3~	634	28	3	50	1162

⁽¹⁾ IE3 compliant

DIMENSIONS

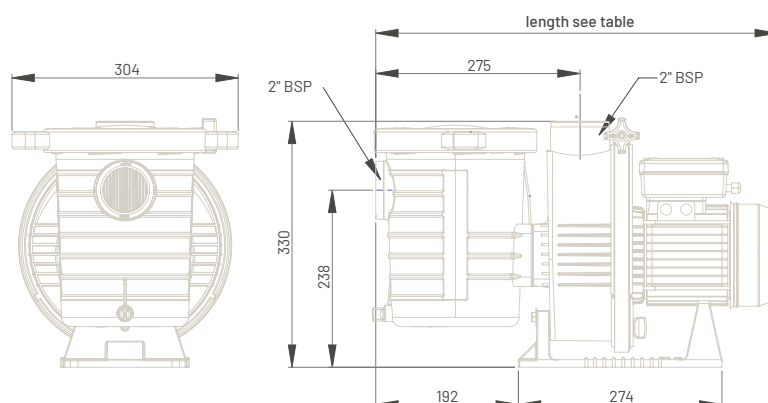

PACKAGING

Part Number	BOX			PALET			
	Length(cm)	Width(cm)	Height(cm)	Length(cm)	Width(cm)	Height(cm)	Pce/Palet
S5P3R...	65	33	38	130	100	165	24
S5P3RH-1 S5P3RH-3E3	80	37.5	60	120	80	165	9

5P6R™, SW5P6R™, INTELLIFLO® SW5P6R™ VSD2

High efficiency, maximum performance and sea water compatibility ([SW] series).



5P6R™ / SW5P6R™



INTELLIFLO® SW5P6R™ VSD2



FEATURES

- XL pre filter basket
- Stainless steel locking clamp
- 1/4 turn opening lid
- Quick self priming

BENEFITS

- ➔ Longer periods between cleanings
- ➔ Easy maintenance
- ➔ Easy opening and locking
- ➔ Quick and safe start of the pump

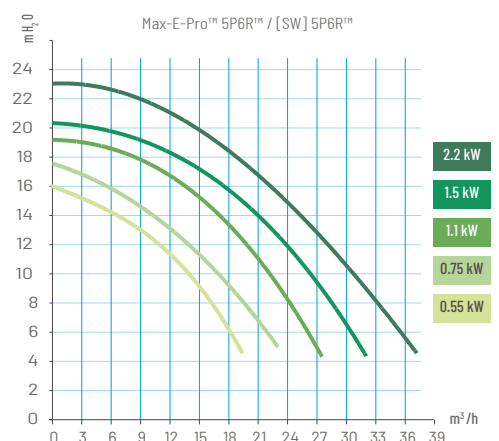
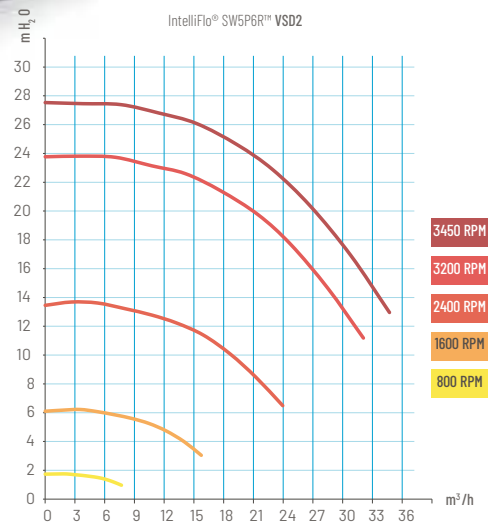

TECHNICAL FEATURES

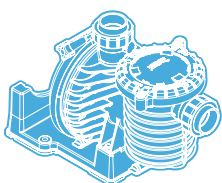

Inlet/Outlet	63 mm threaded
Ø Unions	63 mm ID
Unions included	Yes
Salt resistancy	4.5 % on [SW] serie

TECHNICAL SPECIFICATIONS & PRICE

Part Number	Speed	m ³ / h @ 8 m	Power output P2 (kW) (HP)		Volt (V)	Phase	Length (mm)	Weight (Kg)	Warranty (year)	PIP Points	List Price (€ VAT excl)
STA-RITE™ 5P6R™											
5P6RD-1	Single	16	0,55	0,75	220-240	1~	623	17,0	3	75	830
5P6RD-3	Single	16	0,55	0,75	380-420	3~	623	18,0	3	75	748
5P6RE-1	Single	18	0,75	1	220-240	1~	633	18,0	3	75	872
5P6RE-3E3 ⁽¹⁾	Single	18	0,75	1	380-420	3~	633	26,7	3	75	814
5P6RF-1	Single	24	1,10	1,5	220-240	1~	633	18,7	3	75	954
5P6RF-3E3 ⁽¹⁾	Single	24	1,10	1,5	380-420	3~	633	29,4	3	75	837
5P6RG-1	Single	28	1,50	2	220-240	1~	667	25,0	3	75	1033
5P6RG-3E3 ⁽¹⁾	Single	28	1,50	2	380-420	3~	667	33,2	3	75	983
5P6RH-1	Single	33	2,20	3	220-240	1~	667	26,0	3	75	1109
5P6RH-3E3 ⁽¹⁾	Single	33	2,20	3	380-420	3~	667	36,2	3	75	1089
SW5P6RD-1	Single	16	0,55	0,75	220-240	1~	623	17,0	3	75	1053
SW5P6RD-3	Single	16	0,55	0,75	380-420	3~	623	18,0	3	75	974
SW5P6RE-1	Single	18	0,75	1	220-240	1~	633	18,0	3	75	1079
SW5P6RE-3E3 ⁽¹⁾	Single	18	0,75	1	380-420	3~	633	26,7	3	75	1033
SW5P6RF-1	Single	24	1,10	1,5	220-240	1~	633	18,7	3	75	1166
SW5P6RF-3E3 ⁽¹⁾	Single	24	1,10	1,5	380-420	3~	633	29,4	3	75	1081
SW5P6RG-1	Single	28	1,50	2	220-240	1~	667	25,0	3	75	1253
SW5P6RG-3E3 ⁽¹⁾	Single	28	1,50	2	380-420	3~	667	33,2	3	75	1219
SW5P6RH-1	Single	33	2,20	3	220-240	1~	667	26,0	3	75	1312
SW5P6RH-3E3 ⁽¹⁾	Single	33	2,20	3	380-420	3~	667	36,2	3	75	1313
SW5P6R™-VSD2	IntelliFlo®	38	2.20	3	220-240	1~	740	25,0	3	250	2055

⁽¹⁾ IE3 compliant

DIMENSIONS

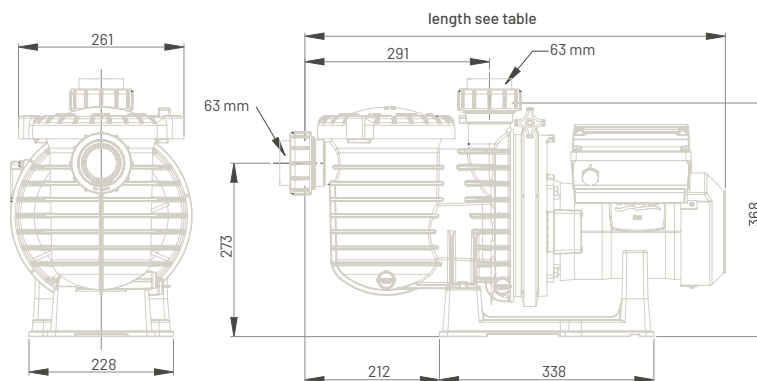

PACKAGING

BOX			PALET			
Length (cm)	Width (cm)	Height (cm)	Length (cm)	Width (cm)	Height (cm)	Pce/Palet
74	37	37	120	80	150	9

5P2R™, S5P2R™, S5P2R™ VS, S5P2R™ VS2

The industry standard and classic from Sta-Rite.

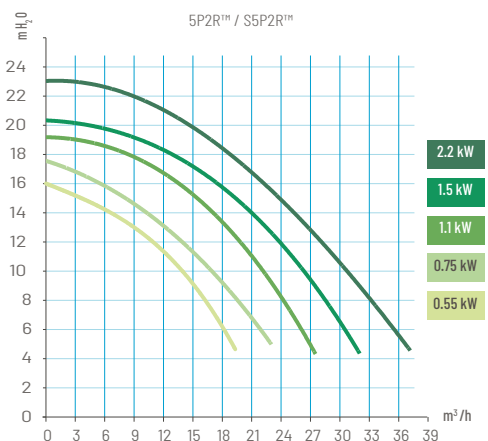
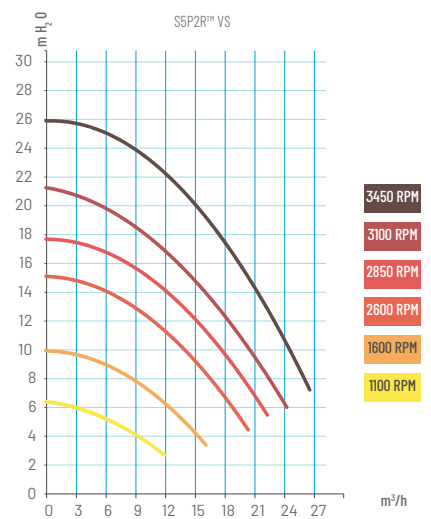
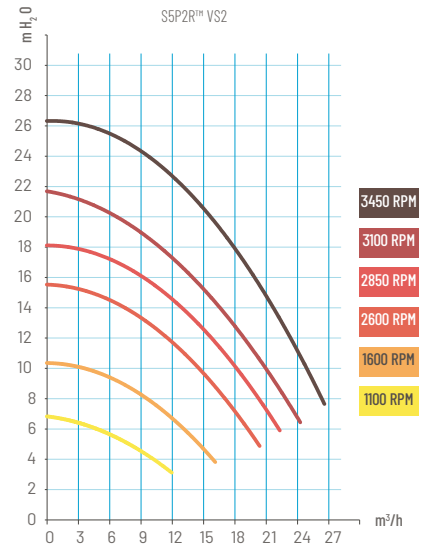
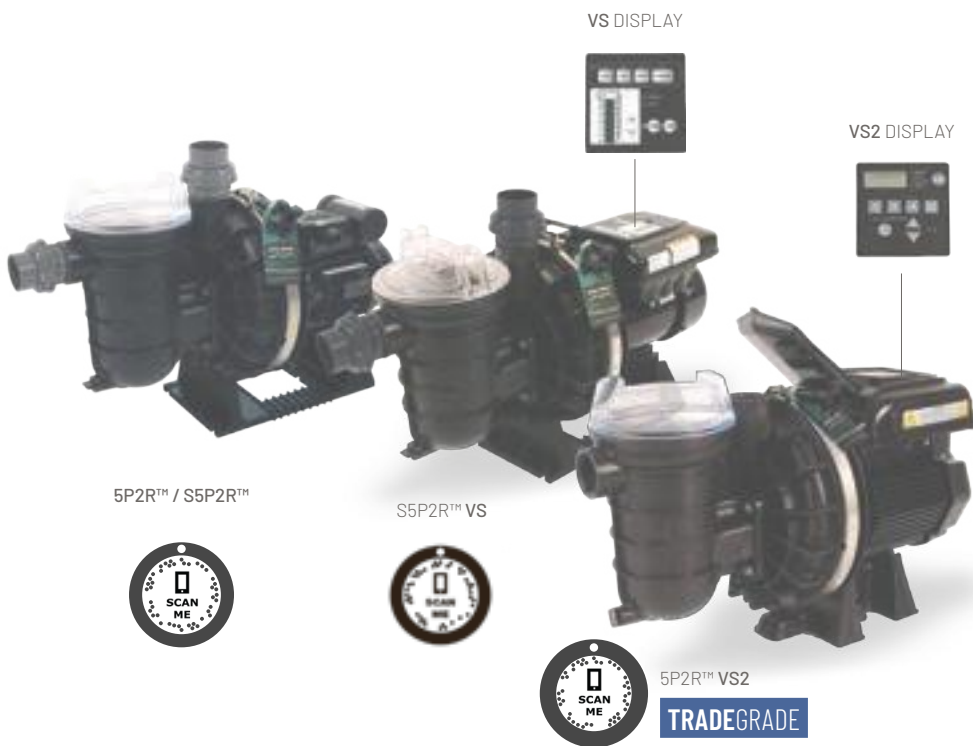

FEATURES

Stainless steel locking clamp

Removable pre filter

XL pre filter basket

BENEFITS

➔ Quick maintenance and upgradability into variable speed pump (with kit S5P2R-CVS)

➔ Possibility to transform the pump into booster pump

➔ Longer periods between cleanings

TECHNICAL FEATURES

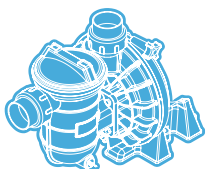

Inlet/Outlet	1.5" BSP
Ø Unions	50 mm ID
Unions included	Yes
Salt resistancy	0,4 % on [S] serie

TECHNICAL SPECIFICATIONS & PRICE

Part Number	Speed	m ³ / h @ 8 m	Power output P2 (kW)	(HP)	Volt (V)	Phase	Length (mm)	Weight (kg)	Warranty (year)	PIP Points	List Price (€ VAT excl)
STA-RITE™ 5P2R™											
5P2RC-1	Single	8	0,37	0,5	220-240	1~	551	15,0	3	50	636
5P2RC-3	Single	8	0,37	0,5	380-420	3~	556	15,0	3	50	636
5P2RD-1	Single	13	0,55	0,75	220-240	1~	551	15,0	3	50	664
5P2RD-3	Single	13	0,55	0,75	380-420	3~	556	12,9	3	50	654
5P2RE-1	Single	16	0,75	1	220-240	1~	561	15,5	3	50	709
5P2RE-3E3 ⁽¹⁾	Single	16	0,75	1	380-420	3~	591	25,7	3	50	730
5P2RF-1	Single	18	1,10	1,5	220-240	1~	561	17,0	3	50	793
5P2RF-3E3 ⁽¹⁾	Single	18	1,10	1,5	380-420	3~	591	26,4	3	50	811
S5P2RC-1	Single	8	0,37	0,5	220-240	1~	551	15,0	3	50	725
S5P2RC-3	Single	8	0,37	0,5	380-420	3~	556	15,0	3	50	706
S5P2RD-1	Single	13	0,55	0,75	220-240	1~	551	15,0	3	50	744
S5P2RD-3	Single	13	0,55	0,75	380-420	3~	556	12,9	3	50	710
S5P2RE-1	Single	16	0,75	1	220-240	1~	561	15,5	3	50	801
S5P2RE-3E3 ⁽¹⁾	Single	16	0,75	1	380-420	3~	591	25,7	3	50	778
S5P2RF-1	Single	18	1,10	1,5	220-240	1~	561	17,0	3	50	858
S5P2RF-3E3 ⁽¹⁾	Single	18	1,10	1,5	380-420	3~	591	26,4	3	50	851
S5P2R-VS	Variable	18	1,10	1,5	220-240	1~	605	24	3	150	1307
S5P2R-VS2	Variable	18	2,70	1,65	220-240	1~	560	22,6	3+1	150+50	1295

⁽¹⁾ IE3 compliant

DIMENSIONS

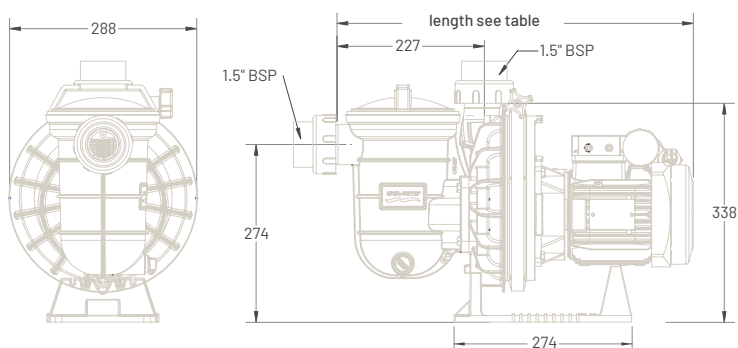

PACKAGING

BOX			PALET			
Length (cm)	Width (cm)	Height (cm)	Length (cm)	Width (cm)	Height (cm)	Pce/Palet
74	37	37	120	80	150	9

5PXF™, INTELLIFLO® 5PXF™ VSF MAX-E-PRO XF® VS

Our high efficiency pumps for semi-commercial applications.

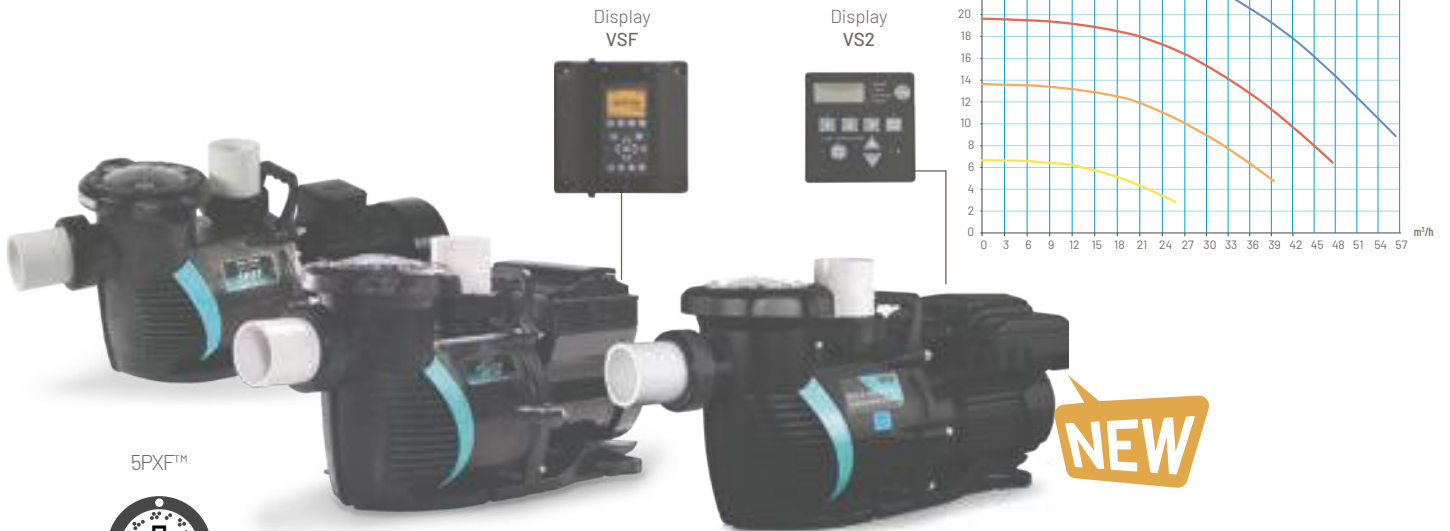

5PXF™



INTELLIFLO® 5PXF™ VSF

TRADEGRADE



MAX-E-PRO XF® VS

TRADEGRADE

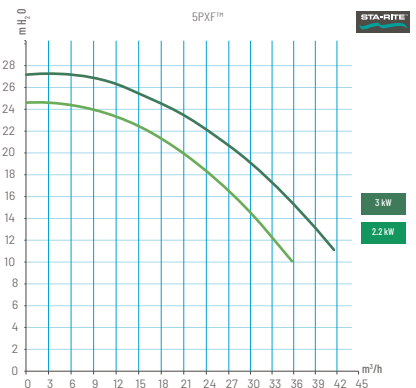
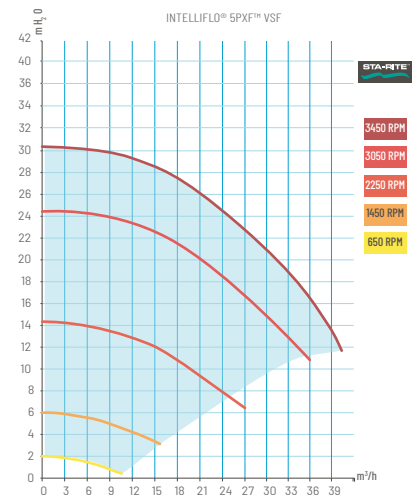
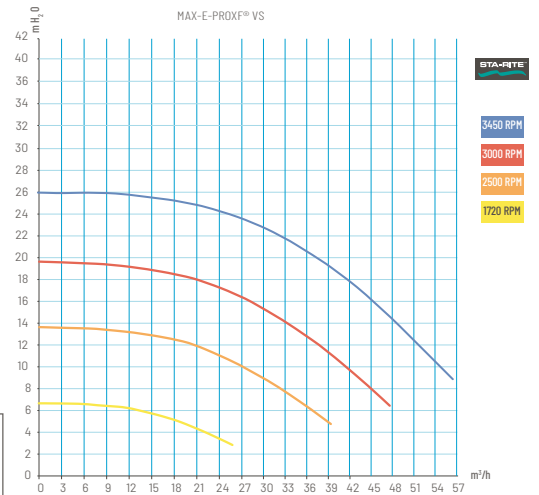

FEATURES

- 1/4 turn opening lid
- XL pre filter basket
- Handle on the top
- Diamond seal
- Hydraulic isolator separating priming water from pumping water

BENEFITS

- ➔ Easy opening and locking
- ➔ Longer periods between cleanings
- ➔ Easy to carry
- ➔ Increased durability and tighter seal
- ➔ Faster priming, less turbulence and increased efficiency

TECHNICAL FEATURES

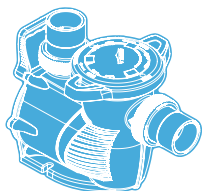

Inlet/Outlet	90 mm threaded
Ø Unions	75 mm or 90mm
Unions included	Yes
Salt resistancy	0,4 %

TECHNICAL SPECIFICATIONS & PRICE

Part Number	Speed	m ³ / h @ 12 m	Power output P2 (kW) HP	Volt (V)	Phase	Length (mm)	Weight (kg)	Warranty (year)	PIP Points	List Price (€ VAT excl)
5PXFH-1	Single	33	2,20 3	220-240	1~	652	23,0	3	100	1444
5PXFH-3E3⁽¹⁾	Single	33	2,20 3	380-420	3~	678	26,0	3	100	1469
5PXFJ-1	Single	40	3,00 4	220-240	1~	715	34,0	3	100	1859
5PXFJ-3E3⁽¹⁾	Single	40	3,00 4	380-420	3~	715	34,0	3	100	1891
5PXF-VSF	IntelliFlo®	42	2,20 3	220-240V	1~	740	28	3+1	250+100	2115
MAX-E-PROXF® VS	Variable	52	3,7 5	220-380V	1~ / 3~	781	42	3	450	3869

⁽¹⁾ IE3 compliant

DIMENSIONS

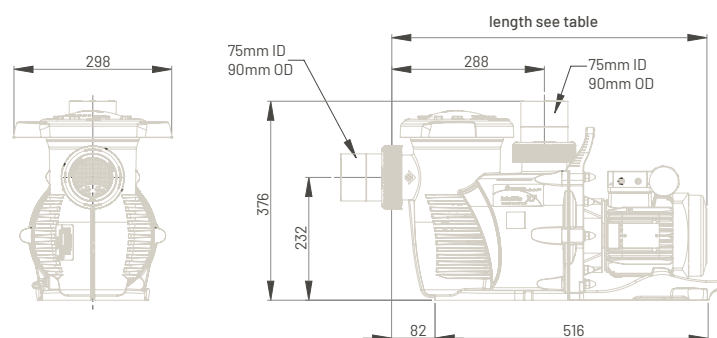

PACKAGING

BOX			PALET			
Length (cm)	Width (cm)	Height (cm)	Length (cm)	Width (cm)	Height (cm)	Pce/Palet
74	37	37	120	80	150	9

SWIMMEY™

Excellent price/quality ratio.
Swiveling unions.



FEATURES

- Quick self priming
- Swivel unions included
- Long cable included

BENEFITS

- ➔ Quick and safe start of the pump
- ➔ Fit also with above-ground pools and easy assembly
- ➔ Easier installation and direct plugging into power socket

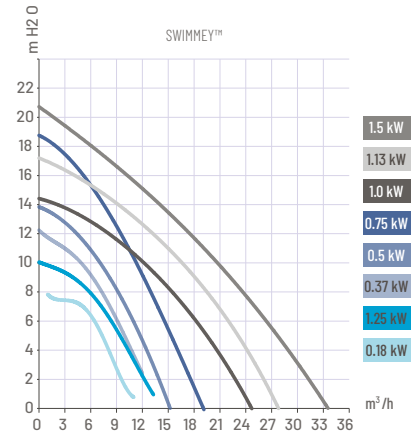

TECHNICAL FEATURES

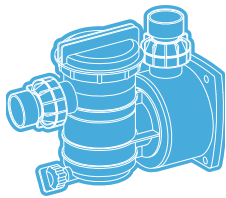

- Inlet/Outlet 50 mm
- Ø Unions 50 mm ID
- Unions included Yes
- Salt resistancy No

DIMENSIONS

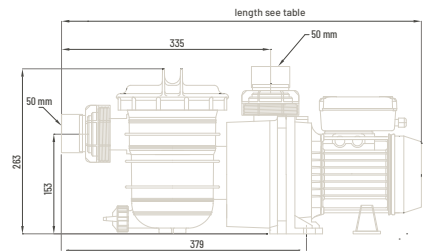

TECHNICAL SPECIFICATIONS & PRICE

Part Number	Speed	m³ / h @ 8 m	Power output P2		Volt (V)	Phase	Length (mm)	Weight (kg)	List Price (€ VAT excl)
			(kW)	(HP)					
P7242380-1	Single	4	0,18	0,25	220-240	1~	565	8,3	275
P7242390-1	Single	6	0,25	0,375	220-240	1~	565	8,4	275
P7242160-1	Single	7	0,375	0,5	220-240	1~	565	8,6	284
P7242170-1	Single	9	0,50	0,75	220-240	1~	565	9,0	313
P7242240-1	Single	9	0,50	0,75	380-420	3~	565	9,0	313
P7242180-1	Single	13	0,75	1	220-240	1~	590	11,2	347
P7242250-1	Single	13	0,75	1	380-420	3~	590	11,2	347
P7242220-1	Single	15	1,00	1,3	220-240	1~	610	11,2	400
P7242270-1	Single	20	1,13	1,5	220-240	1~	635	13,0	466
P7242280-1	Single	20	1,13	1,5	380-420	3~	635	13,0	466
P7242290-1	Single	24	1,50	2	220-240	1~	635	14,5	547
P7242300-1	Single	24	1,50	2	380-420	3~	635	14,5	547

PACKAGING

Powers	BOX			PALET				
	HP	Length (cm)	Width (cm)	Height (cm)	Length (cm)	Width (cm)	Height (cm)	Pce/Palet
0.25 → 0,50		57	20	32	120	80	180	40
1		59	20	32	120	80	180	40
1.3		61	20	32	120	80	180	40
1.5 → 2		64	20	32	120	80	180	40

FREEFLO™

Simplicity and efficiency for in-ground and above-ground pools. Swiveling unions.



FEATURES

- 1/4 turn opening lid
- XL pre filter basket
- Quick self priming
- Swivel unions included

- Long cable included
- 90° rotatable pump discharge

BENEFITS

- ➔ Easy opening and locking
- ➔ Easier and less-frequent maintenance
- ➔ Quick and safe start of the pump
- ➔ Fit also with above-ground pools and easy assembly
- ➔ Easier installation and direct plugging into power socket
- ➔ Allow customized installation

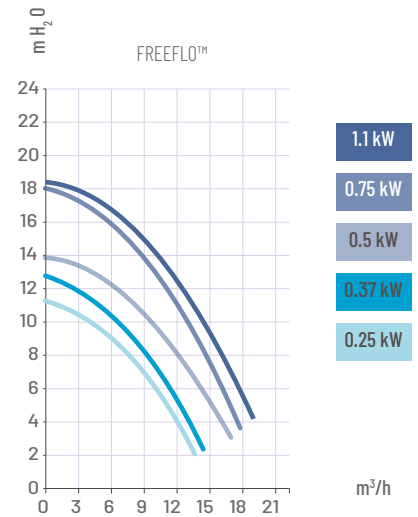

TECHNICAL FEATURES

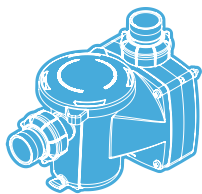

- Inlet/Outlet 50 mm
- Ø Unions 50 mm ID.
- Unions included Yes
- Salt resistancy No

DIMENSIONS

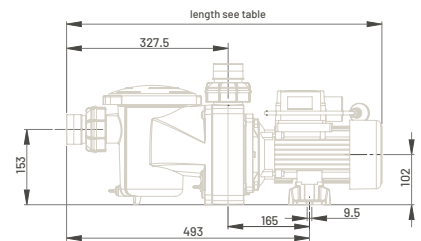

TECHNICAL SPECIFICATIONS & PRICE

Part Number	Speed	m ³ / h @ 8 m	Power output P2		Volt (V)	Phase	Length (mm)	Weight (Kg)	List Price (€ VAT excl)
			(kW)	(HP)					
FFL-031	Single	7	0,25	0.375	220-240	1~	540	10,0	274
FFL-051	Single	9	0,375	0.5	220-240	1~	540	10,5	284
FFL-071	Single	12	0,55	0.75	220-240	1~	562	11,5	315
FFL-101	Single	14	0,75	1	220-240	1~	562	12,5	349
FFL-151	Single	16	1,10	1,5	220-240	1~	600	14,5	467

PACKAGING

Powers	BOX			PALET				
	HP	Length (cm)	Width (cm)	Height (cm)	Length (cm)	Width (cm)	Height (cm)	Pce/Palet
0.25 → 0.75		64,5	24	32.5	120	100	108	18
1 → 1.5		69	24	32.5	120	100	108	18

BLUEFLO[®], BLUEFLO[®] LITE

The booster pumps that increase your pressure cleaner's performances.



FEATURES

- Body of pump in fiberglass reinforced polypropylene
- Integrated ON/OFF switch and power cord supplied
- Large sealed 2RSC3 type bearings
- AINSI316 stainless steel motor shaft and metal free impellers
- Integrated Electronic Protection Logic -Safe (BlueFlo)

Compatible inlet/outlet positions

BENEFITS

- High pressure resistance
- Safe and easy installation
- High thermal resistance
- Corrosion resistant
- Avoid dry running, motor overload and water temperature overheating
- Ideal replacement of Sta-Rite Boostrite, Polaris*, DAB** EuroCom booster pumps

TECHNICAL SPECIFICATIONS

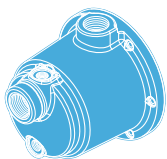

Inlet/Outlet	1" BSP tapped
Ø Unions	32 mm
Salt resistancy	0,4 %

* © Fluidra

** © DAB

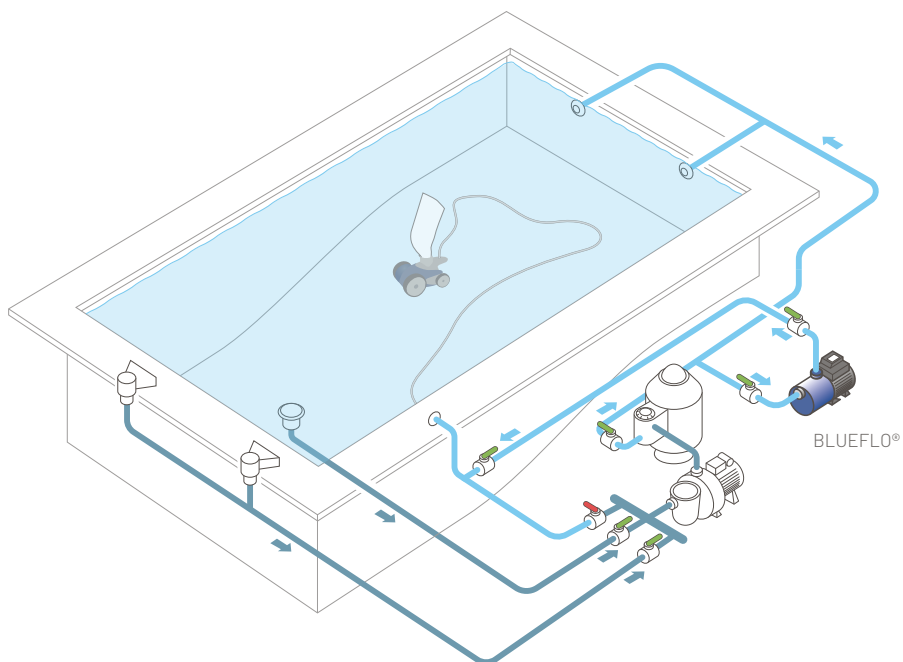

TECHNICAL SPECIFICATIONS & PRICE

Part Number	Power output P2		Volt (V)	Phase	Nb of Turbines	Length (mm)	Height (mm)	Weight (Kg)	Warranty (year)	PIP Points	List Price (€ VAT excl)
	(kW)	(HP)									
BLUEFLO											
P-BFL-101	0,75	1	220V-240	1~	4	373	221	9,0	2+1	75+25	387
P-BFL-151	1,10	1,5	220-240	1~	5	392	229	10,8	2+1	75+25	431
BLUEFLO LITE											
P-BFL-101-L	0.75	1	220V-240	1~	4	373	199	8,5	2	75	333

DIMENSIONS

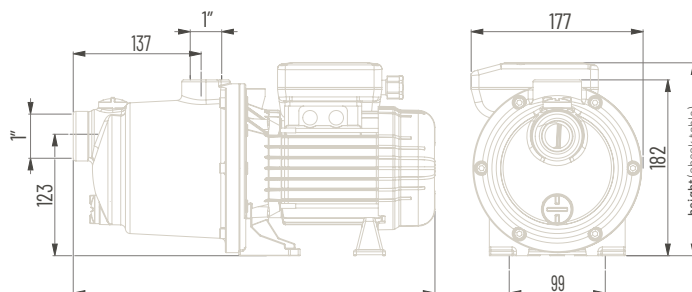

PACKAGING

BOX			PALET			
Length (cm)	Width (cm)	Height (cm)	Length (cm)	Width (cm)	Height (cm)	Pce/Palet
57 / 59 / 61 / 64	20	38	120	80	180	40

CLEARPRO TECHNOLOGY® PENTAIR

ClearPro is a patented technology that allows to reach fine level of filtration 4 times better than conventional sand filters.

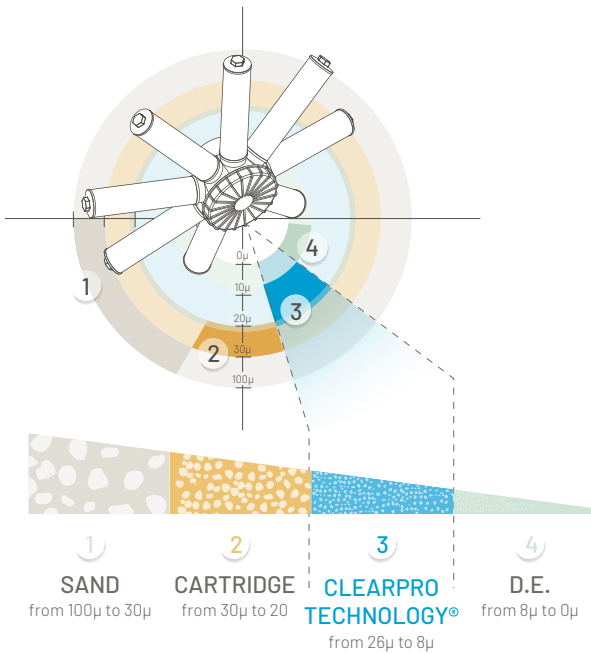

- ◆ 10µ filtration VS 40µ for conventional sand filters.

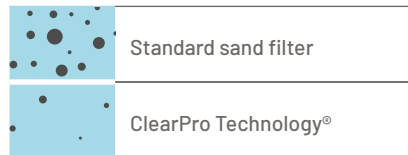

- ◆ The ClearPro laterals act like additional filters creating an extra barrier against the finest particles
- ◆ Water is crystal clear

ClearPro approaches DE filter clarity with the simplicity of sand filter.

PRODUCTS AVAILABLE WITH CLEARPRO TECHNOLOGY®

EXCLUSIVITY **TRADEGRADE**



TRITON® NEO PROVALVE



TRITON® NEO SM



TRITON® NEO TM



POSEIDON™

SWIMMING POOL FILTERS

Sand, D.E., Cartridge

SAND FILTERS

CRISTAL-FLO™ TM & SM.....	38
AZUR™	40
POSEIDON™	41
TRITON® SM & TAGELUS® TM	42
TRITON® NEO SM & TM.....	44
TRITON® NEO WITH PROVALVE	46

D.E. FILTERS

QUAD D.E.®	47
------------------	----

CARTRIDGE FILTERS

CLEAN & CLEAR™ / CLEAN & CLEAR™ PLUS	48
POSI-CLEAR™ RP	50
SYSTEM 2™	51

SAND FILTRATION SYSTEMS

CRISTAL-FLO™ with FREEFLO™ or SWIMMEY™ PUMP	52
AZUR™ with FREEFLO™ or SWIMMEY™ PUMP	54



CRISTAL-FLO™ TM & SM



The high-end blow-molded filter.

FEATURES

- ◆ One-piece and extra-thick blow-molded polyethylene tank.
- ◆ Easier maintenance thanks to the large filter opening.
- ◆ Stainless steel one piece clamp connection.
- ◆ Large drain port for easy service and winterizing.
- ◆ PRAHER 6 way valve in recycled ABS.
- ◆ Max working pressure : 2,3 bars.

TECHNICAL FEATURES & PRICE

Part number	Diameter Ø (mm)	Filter area (m ²)	Flow rate (m ³ /h)	Max pressure (bars)	Valve connection	Sand (kg) 0.4 - 0.8 mm	Clearance distance (mm)	Valve	List Price (€ excl. VAT)
CRISTAL-FLO™ TM									
KIT-T-380	380	0,12	5	2,3	50 mm	48	800	6 way	397
KIT-T-430	430	0,15	7,4	2,3	50 mm	70	960	6 way	418
KIT-T-500	500	0,20	9,8	2,3	50 mm	90	1000	6 way	433
KIT-T-600	600	0,29	14,2	2,3	50 mm	140	1100	6 way	456
TM-760	762	0,45	22	2,3	2"	260	1300	6 way	787
CRISTAL-FLO™ SM									
KIT-SM-430	430	0,15	7,4	2,3	1½"	70	960	6 way	490
KIT-SM-500	500	0,20	9,8	2,3	1½"	90	1000	6 way	514
KIT-SM-600	600	0,29	14,2	2,3	1½"	140	1100	6 way	538
SM-760	762	0,45	22,5	2,3	2"	260	1250	6 way	1021

Valve included



DIMENSIONS

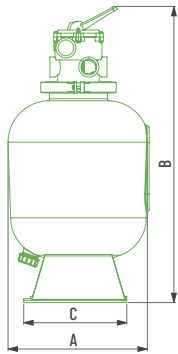

Part number	A (mm)	B (mm)	C (mm)
KIT-T-380	Ø 405	750	400
KIT-T-430	Ø 455	880	400
KIT-T-500	Ø 525	950	400
KIT-T-600	Ø 625	1050	400
TM-760	Ø 762	1170	610

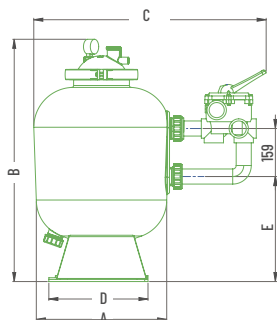

Part number	A (mm)	B (mm)	C (mm)	D (mm)	E (mm)
KIT-SM-430	Ø 455	840	750	400	540
KIT-SM-500	Ø 525	880	820	400	550
KIT-SM-600	Ø 625	980	920	400	585
SM-760	Ø 762	1120	1090	610	630

PACKAGING

Part number	BOX				PALET			
	Length (cm)	Width (cm)	Height (cm)	Weight (kg)	Length (cm)	Width (cm)	Height (cm)	Pce/Palet

CRISTAL-FLO™ TM

KIT-T-380	41	44	69	11	120	84	146	8
KIT-T-430	47	47	96	14	120	100	160	8
KIT-T-500	54	54	100	19	130	110	170	8
KIT-T-600	63	63	110	25	120	80	210	4
TM-760	78	78	120	28,3	156	156	134	2

CRISTAL-FLO™ SM

KIT-SM-430	47	47	96	14	117	117	185	8
KIT-SM-500	54	54	100	19	130	110	170	8
KIT-SM-600	63	63	110	25	128	110	170	4
SM-760	78	784	120	38	156	156	134	2



Best price/quality ratio of blow-molded filters.

FEATURES

- ◆ One-piece and extra-thick blow-molded polyethylene tank.
- ◆ Available in Top-Mount (TM) only.
- ◆ Designed for both in-ground and above-ground pools.
- ◆ Large drain port for easy service and winterizing.
- ◆ PRAHER 6 way valve in ABS.
- ◆ Max working pressure : 2,0 bars.

TECHNICAL FEATURES & PRICE

Part number	Diameter Ø (mm)	Filter area (m²)	Flow rate (m³/h)	Max pressure (bars)	Valve connection	Sand (kg) 0.4 - 0.8 mm	Gravel (kg) 3- 5 mm	Clearance distance (mm)	Valve	List Price (€ excl. VAT)
F-15TF-AZ	375	0,11	6	2,0	1½"	30	12	786	6 way	395
F-19TF-AZ	475	0,18	9	2,0	1½"	65	15	1009	6 way	408
F-22TF-AZ	560	0,25	12	2,0	1½"	120	20	1154	6 way	427
F-26TF-AZ	660	0,35	16,5	2,0	1½"	225	20	1295	6 way	617

Top-mounted valve included

DIMENSIONS

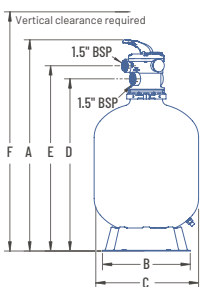

Part number	A (mm)	B (mm)	C (mm)	D (mm)	E (mm)	F (mm)
F-15TF-AZ	701	sans base	Ø 375	533	592	955
F-19TF-AZ	924	400	Ø 475	768	827	1178
F-22TF-AZ	1069	400	Ø 560	915	972	1374
F-26TF-AZ	1210	489	Ø 660	1054	1111	1667



PACKAGING

Part number	BOX				PALET			
	Length (cm)	Width (cm)	Height (cm)	Weight (kg)	Length (cm)	Width (cm)	Height (cm)	Pce/Palet
F-15TF-AZ	40	40	75	7,5	80	120	162	12
F-19TF-AZ	49	49	89	13,0	100	120	238	8
F-22TF-AZ	58	58	103	16,0	125	125	220	8
F-26TF-AZ	65	86	118	19,0	80	120	124	2

POSEIDON™

TRADEGRADE



New generation of sand filter.

FEATURES

- ◆ Thermoplastic injected filter with 100% food grade polypropylene.
- ◆ A 360° diffuser to keep the sand bed flat for optimum filtration, has a swingaway design for instant access to Sand.
- ◆ Easy to use water drain for simplified service and winterizing.
- ◆ Tool free maintenance with clamp locked by butterfly screws and nuts.
- ◆ Transparent dome.
- ◆ Available in Side-mount (SM) only.
- ◆ PRAHER 6 way valve in recycled ABS.
- ◆ Max working pressure : 2,0 bars.

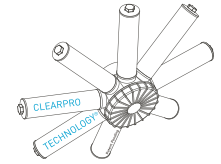

Available with ClearPro Technology®

TECHNICAL FEATURES & PRICE

Part number		Diameter Ø (mm)	Filter area (m ²)	Flow rate (m ³ /h)	Max pressure (bars)	Valve connection	Sand (kg) 0.4 - 0.8 mm	Clearance distance (mm)	Valve	List Price (€ excl. VAT)	
Standard	ClearPro									Standard	ClearPro
F-PIF-500	F-PIF-500CP	530	0,21	10,5	2	1 ½"	100	950	6 way	528	644
F-PIF-600	F-PIF-600CP	620	0,28	14	2	1 ½"	150	980	6 way	601	732
F-PIF-800	F-PIF-800CP	790	0,44	22	2	2"	235	1150	6 way	1065	1299

Valve included

Warranty (years)		PIP Points	
Standard	ClearPro	Standard	ClearPro
5	(5)+5	30	(30)+45

DIMENSIONS

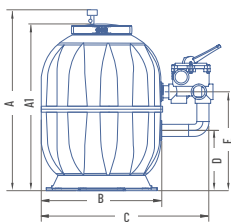

Part number	A (mm)	AI (mm)	B (mm)	C (mm)	D (mm)	E (mm)
F-PIF-500...	795	735	Ø 530	730	281	431
F-PIF-600...	830	768	Ø 620	820	300	449
F-PIF-800...	1010	955	Ø 790	1102	349	579



PACKAGING

Part number		BOX				PALET			
Standard	ClearPro	Length (cm)	Width (cm)	Height (cm)	Weight (kg)	Length (cm)	Width (cm)	Height (cm)	Pce/Palet
F-PIF-500	F-PIF-500CP	72	55	74	9	109	100	235	12
F-PIF-600	F-PIF-600CP	64	64	95	11	128	100	202	8
F-PIF-800	F-PIF-800CP	82	82	111	21	163	100	235	4

TRITON® SM & TAGELUS® TM



The industry standard.

FEATURES

- ◆ One piece, fiberglass reinforced tank with UV resistant coating.
- ◆ Seamless composite construction eliminate risks of leaks, rust or corrosion.
- ◆ A 360° diffuser keeps the sand bed flat for optimum filtration, has a swingaway design for instant access to Sand.
- ◆ Easy to use water drain for simplified service and winterizing.
- ◆ Filter fittings are threaded for easy servicing.
- ◆ New manometer in stainless steel casing mounted on the 6-way valve.
- ◆ Re-inforced inner pipes & adaptor rings.
- ◆ PRAHER 6 way valve in recycled ABS.
- ◆ Max working pressure : 2.3 bars.

! ONLY WITH TAGELUS TM

- ◆ 6 way valve with sight glass, built-in pressure gauge, manual air relief valve, Pipe connections and clamp ring.

TECHNICAL FEATURES & PRICE

Part number	Diameter Ø (mm)	Filter area (m²)	Flow rate (m³/h)	Max pressure (bars)	Valve connection	Sand (kg) 0.4 - 0.8 mm	Gravel (kg) 3- 5 mm	Clearance distance (mm)	Valve	List Price (€ excl. VAT)
TRITON® SM										
F-19S8-TRV	480	0,17	8,5	2.3	1½"	50	25	825	6 way	738
F-24S8-TRV	610	0,29	14	2.3	1½"	100	50	955	6 way	868
F-30S8-TRV	762	0,45	22	2.3	2"	200	75	1095	6 way	1283
KIT-F-36S8-TRV	914	0,64	32	2.3	2"	300	100	1200	6 way	1777
TAGELUS® TM										
F-19T6-TAG	480	0,17	8,5	2.3	1½"	50	25	985	6 way	520
F-24T6-TAG	610	0,29	14	2.3	1½"	100	50	1115	6 way	623
F-30T8-TAG	762	0,45	22	2.3	2"	200	75	1286	6 way	927

Valve included



	PIP Points
TRITON® SM	75
TAGELUS® TM	50

DIMENSIONS

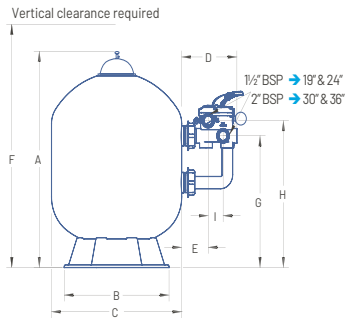

Part number	A (mm)	B (mm)	C (mm)	D (mm)	E (mm)	F (mm)	G (mm)	H (mm)	I (mm)
TRITON® SM									
F-19S8-TRV	770	400	Ø 480	252	120	876	463	524	70
F-24S8-TRV	900	400	Ø 610	252	120	1006	530	592	70
F-30S8-TRV	1040	610	Ø 762	302	160	1146	590	671	70
KIT-F-36S8-TRV	1145	610	Ø 914	302	160	1251	657	738	70

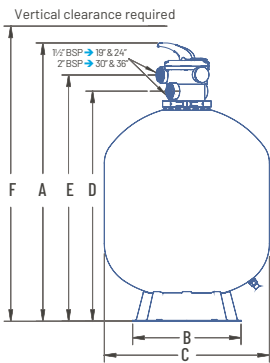

Part number	A (mm)	B (mm)	C (mm)	D (mm)	E (mm)	F (mm)
TAGELUS® TM						
F-19T6-TAG	878	400	Ø 480	715	774	1194
F-24T6-TAG	1009	400	Ø 610	847	904	1448
F-30T8-TAG	1170	610	Ø 762	1026	1108	1664

PACKAGING

Part number	BOX				PALET			
	Length (cm)	Width (cm)	Height (cm)	Weight (kg)	Length (cm)	Width (cm)	Height (cm)	Pce/Palet
TRITON® SM								
F-19S8-TRV	49	49	88	13,4	117	117	185	8
F-24S8-TRV	54	54	102	18,4	130	110	170	8
F-30S8-TRV	63	63	120	29,8	128	110	170	4
KIT-F-36S8-TRV	78	784	106	35,5	156	156	134	2
TAGELUS® TM								
F-19T6-TAG	41	44	69	11	120	84	146	8
F-24T6-TAG	47	47	96	14	120	100	160	8
F-30T8-TAG	54	54	100	19	130	110	170	8

TRITON® NEO SM & TM

TRADEGRADE



The improved version of the Industry standard.

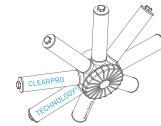

NEW FEATURES

- ◆ New manometer in stainless steel casing mounted on the dome.
- ◆ Max working pressure: 3.5 bars.
- ◆ New metallic blue colour with shiny gloss, UV resistant.
- ◆ Reinforced inner packaging.
- ◆ Available with ClearPro Technology® and Provalve.

⚠ ONLY WITH TRITON NEO SIDE (SM)

- ◆ Pre-assembled ABS 6-way valve.
- ◆ New dome with independent connection for manometer and air bleed.
- ◆ New full plastic anti-corrosion air bleed with extra air-tube to keep shell clean.
- ◆ Re-inforced inner pipes & adaptor rings.

TECHNICAL FEATURES & PRICE

Part number		Diameter Ø (mm)	Filter area (m²)	Flow rate (m³/h)	Max pressure (bars)	Valve connection	Sand (kg) 0.4 - 0.8 mm	Gravel (kg) 3 - 5 mm	Clearance distance (mm)	Valve	List Price (€ excl. VAT)	
Standard	ClearPro										Standard	ClearPro
TRITON® NEO SM												
F-19S8-NEO	F-19S8-NEOCP	480	0,17	8,5	3,5	1.5"	50	25	825	6 way	730	791
F-24S8-NEO	F-24S8-NEOCP	610	0,29	14	3,5	1.5"	100	50	955	6 way	859	931
F-30S8-NEO	F-30S8-NEOCP	762	0,45	22	3,5	2"	200	75	1095	6 way	1269	1378
KIT-F-36S8-NEO	KIT-F-36S8-NEOCP	914	0,64	32	3,5	2"	300	100	1200	6 way	1758	1907

TRITON® NEO TM

F-19T6-NEO	F-19T6-NEOCP	480	0,17	8,5	3,5	1.5"	50	25	985	6 way	514	555
F-24T6-NEO	F-24T6-NEOCP	610	0,29	14	3,5	1.5"	100	50	1115	6 way	616	667
F-30T8-NEO	F-30T8-NEOCP	762	0,45	22	3,5	2"	200	75	1286	6 way	917	991

Valve included ⚠ (1) No gravel with Clearpro technology

	PIP Points	
	Standard	ClearPro
TRITON® NEO SM	(75)+50	(75)+125
TRITON® NEO TM	(50)+50	(50)+75





DIMENSIONS

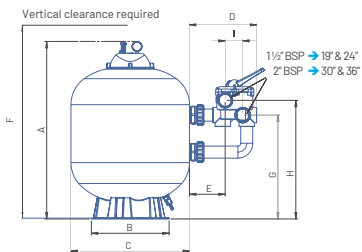

Part number	A (mm)	B (mm)	C (mm)	D (mm)	E (mm)	F (mm)	G (mm)	H (mm)	I (mm)
TRITON® NEO SM									
F-19S8-NEO...	785	400	∅ 480	252	120	876	463	524	70
F-24S8-NEO...	915	400	∅ 610	252	120	1006	530	592	70
F-30S8-NEO...	1055	610	∅ 762	302	160	1146	590	671	70
KIT-F-36S8-NEO...	1160	610	∅ 914	302	160	1251	657	738	70

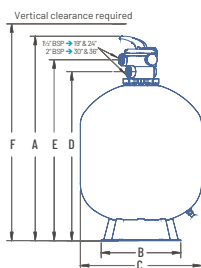

Part number	A (mm)	B (mm)	C (mm)	D (mm)	E (mm)	F (mm)
TRITON® NEO TM						
F-19T6-NEO...	878	400	∅ 480	715	774	1194
F-24T6-NEO...	1009	400	∅ 610	847	904	1448
F-30T8-NEO...	1170	610	∅ 762	1026	1108	1664

PACKAGING

Part number		BOX				PALET			
Standard	ClearPro	Length (cm)	Width (cm)	Height (cm)	Weight (kg)	Length (cm)	Width (cm)	Height (cm)	Pce/Palet
TRITON® NEO SM									
F-19S8-NEO	F-19S8-NEOCP	49	49	88	13.4	98	98	189	8
F-24S8-NEO	F-24S8-NEOCP	63	63	102	18.4	126	126	218	8
F-30S8-NEO	F-30S8-NEOCP	78	78	120	29.8	156	80	134	2
KIT-F-36S8-NEO	KIT-F-36S8-NEOCP	94	94	106	35.5	95	95	220	2
TRITON® NEO TM									
F-19T6-NEO	F-19T6-NEOCP	49	49	88	11	98	98	189	8
F-24T6-NEO	F-24T6-NEOCP	63	63	102	16.3	126	126	218	8
F-30T8-NEO	F-30T8-NEOCP	78	78	120	28.3	156	80	134	2

TRITON® NEO WITH PROVALVE



Triton NEO with automated backwash valve.

FEATURES

- ◆ The Pentair Pro Valve enables external control systems such as IntelliPool to perform automated filter backwash.
- ◆ Operated pneumatically in both ways.
- ◆ Automatic return to filtration position in case of power failure. (no possible pool emptying)
- ◆ 220-240 VAC operated pilot valve.
- ◆ Tubing and connectors included.
- ◆ 2" port enabling low head loss.
- ◆ 63 mm unions included.
- ◆ Robust design rated up to 6 bars.
- ◆ Port can be 90° turned to facilitate installation.
- ◆ Adapter (PROV-ADAP) available for direct mount on existing Triton.
- ◆ Max working pressure : 3.5 bars.

TECHNICAL FEATURES & PRICE

Part number	Description	List Price (€ excl. VAT)
PROVALVE		
PROV-1010	2" ProValve Kit with unions ⁽¹⁾	1088
TRITON® NEO WITH CLEARPRO TECHNOLOGY® AND PROVALVE		
F-24S8-NEOCP PRO	24" Triton NEO ClearPro with Pro Valve	1851
F-30S8-NEOCP PRO	30" Triton NEO ClearPro with Pro Valve	2232
F-36S8-NEOCP PRO	36" Triton NEO ClearPro with Pro Valve	2728

⁽¹⁾ PROV-ADAP is required to install on existing Triton.

Sea water version (4,5%) available on demand. Please contact your local Pentair representant. ClearPro Technology at standard Triton price.

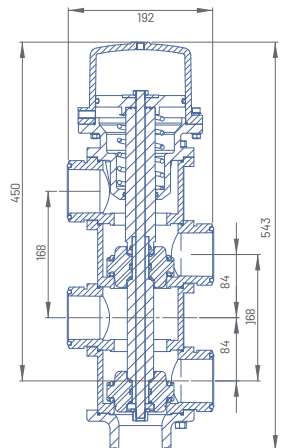

DIMENSIONS

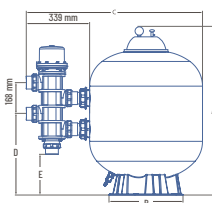

Part number	A (mm)	B (mm)	C (mm)	D (mm)	E (mm)
F-24S8-NEOCP PRO	915	Ø 400	949	438	211
F-30S8-NEOCP PRO	1055	Ø 610	1101	498	271
F-36S8-NEOCP PRO	1160	Ø 610	1253	565	338



ACCESSOIRES

Part number	Description	List Price (€ excl. VAT)
PROV-ADAP	Retro-Fit Adaptor for Triton standard and neo (2pcs)	238
PROV-CPR	Pro Valve Compressor (135 x 254 x 220 mm / 3,8 bar)	269



Compressor minimum requirements, Pressure = 2,2-3,8 bar

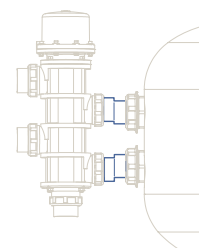

QUAD D.E.®



The highest clarity of water with the lowest amount of fuss.

FEATURES

- ◆ Four large-capacity cartridges provide maximum filter surface area for greater dirt-trapping capacity and longer periods between cleanings.
- ◆ Chemical resistant, fiberglass-reinforced polypropylene tank for exceptional strength and long life.
- ◆ Water flows through the Quad D.E. Cartridge Style Filters so efficiently that your pump will use less energy.
- ◆ Unique internal flow path ensures optimum filtration and backwashing efficiency.
- ◆ Available as accessory : DE Separation Tank.
- ◆ Max working pressure : 3,5 bars.

TECHNICAL FEATURES & PRICE

Part number	Diameter Ø (mm)	Filter area (m ²)	Flow rate (m ³ /h)	Max pressure (bars)	Valve connection	Clearance distance (mm)	Valve	List Price (€ excl. VAT)
H-18-8592/4	546	5,6	20,4	3,5	2"	1575	6 way	1440

Valve not included → See Accessories section

PACKAGING

BOX				PALET			
Length (cm)	Width (cm)	Height (cm)	Weight (kg)	Length (cm)	Width (cm)	Height (cm)	Pce/Palet
57	57	100	30,0	115	115	110	4

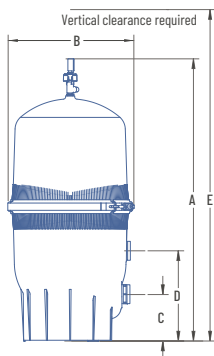

DIMENSIONS

A (mm)	B (mm)	C (mm)	D (mm)	E (mm)
1092	Ø 546	203	394	1575



QUAD D.E.®
H-18-8592/4

ACCESSORIES

Part number	Description	List Price (€ excl. VAT)
RE26107IND	6 way black valve 2"	252
300005-EU	SEP 100™ DE Separation Tank	428

Cartridges included → See page : 111



SEP 100™ D.E. SEPARATION TANK
300005-EU

CLEAN & CLEAR™ / CLEAN & CLEAR™ PLUS



Fine filtration, minimum maintenance, low head loss, Clean & Clear cartridge filters are a perfect match with variable speed pumps.

FEATURES

- ◆ Corrosion-resistant, injection-molded, fiberglass-reinforced, polypropylene filter tank featuring superior strength and reliability.
- ◆ Single-piece base and body design for more stability.
- ◆ Integrated Continuous High Flow™ Internal Air Relief.
- ◆ **Clean & Clear** uses a coreless cartridge for easy cleaning.
- ◆ **Clean & Clear Plus** uses 4 cartridges for an increased filter area and a better dirt capacity, which increase the period between washings.

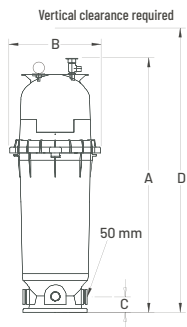

CLEAN & CLEAR™ PLUS

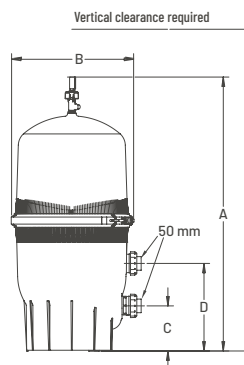

DIMENSIONS

Part number	A (mm)	B (mm)	C (mm)	D (mm)
H-16-0314	457	394	70	762
H-16-0315	648	394	70	991
H-16-0316	838	394	70	1550
H-16-0317	1029	394	70	1930
H-16-0318	1029	394	70	1930

DIMENSIONS

Part number	A (mm)	B (mm)	C (mm)	D (mm)	E (mm)
H-16-0310	940	546	203	394	1422
H-16-0340	1092	546	203	394	1575
H-16-0301	1244	546	203	394	1727
H-16-0332	1422	546	203	394	1880

TECHNICAL FEATURES & PRICE

Part number	Model	Diameter Ø (mm)	Flow rate (m³/h)	Filter area (m²)	Max pressure (bars)	Pipe connection (mm)	Clearance distance (mm)	Cartridge part number	List Price (€ excl. VAT)
CLEAN & CLEAR™									
H-16-0314	CC50	394	5,7	4,7	3,5	ID 50 - OD 63	762	H-RAF173213	315
H-16-0315	CC75	394	8,5	7,0	3,5	ID 50 - OD 63	991	H-RAF173214	381
H-16-0316	CC100	394	11,4	9,3	3,5	ID 50 - OD 63	1550	H-RAF173215	418
H-16-0317	CC150	394	17,0	13,9	3,5	ID 50 - OD 63	1930	H-RAF173216	482
H-16-0318	CC200	394	22,7	18,6	3,5	ID 50 - OD 63	1930	H-RAF173217	515
CLEAN & CLEAR™ PLUS									
H-16-0310	CC+240	546	27,3	22,3	3,5	ID 50 - OD 63	1422	H-RAF173572	809
H-16-0340	CC+320	546	29,8	29,7	3,5	ID 50 - OD 63	1575	H-RAF173573	869
H-16-0301	CC+420	546	32,0	39,0	3,5	ID 50 - OD 63	1727	H-RAF173576	958
H-16-0332	CC+520	546	34,0	48,3	3,5	ID 50 - OD 63	1880	H-RAF173578	1040

Cartridges included

PACKAGING

Part number	BOX				PALET			
	Length (cm)	Width (cm)	Height (cm)	Weight (kg)	Length (cm)	Width (cm)	Height (cm)	Pce/Palet
CLEAN & CLEAR™								
H-16-0314	36	36	47	6,8	115	115	107	18
H-16-0315	36	36	68	11,8	115	115	149	18
H-16-0316	36	36	85	15,0	115	115	183	18
H-16-0317	36	36	105	15,9	115	115	223	18
H-16-0318	36	36	105	16,2	115	115	223	18
CLEAN & CLEAR™ PLUS								
H-16-0310	58	58	113	27,0	115	115	128	4
H-16-0340	58	58	113	31,8	115	115	128	4
H-16-0301	58	58	113	36,0	115	115	128	4
H-16-0332	58	58	128	40,8	115	115	143	4

POSI-CLEAR™ RP



The most efficient cartridge filters.

FEATURES

- ◆ 50% more efficiency than any other single cartridge filter available.
- ◆ Increased cartridge surface consistency to block and trap particles as small as 20 microns.
- ◆ Posi-Ring closure for easy and safe access to the cartridge for seasonal maintenance.
- ◆ Easy and safe cartridge removal and maintenance.
- ◆ Integrated Continuous High-flow Manual Air Relief Valve.
- ◆ Single-piece, fiberglass-reinforced polypropylene tank for strength and corrosion resistance.
- ◆ Pipe connection unions include.
- ◆ Max working pressure: 3,5 bars.

TECHNICAL FEATURES & PRICE

Part number	Diameter Ø (mm)	Filter area (m2)	Flow rate (m³/h)	Max pressure (bars)	Pipe connection	Clearance distance (mm)	Cartridge part number	Max temperature	List Price (€ excl. VAT)
PXC-RP100	394	9,3	22,7	3,5	50/60mm ID 2" - OD 2.5"	1550	H-RAF173215	40°C	456
PXC-RP150	394	13,9	34,1	3,5	50/60mm ID 2" - OD 2.5"	1930	H-RAF173216	40°C	528
PXC-RP200	394	18,6	34,1	3,5	50/60mm ID 2" - OD 2.5"	1930	H-RAF173217	40°C	561

Cartridges included

PACKAGING

Part number	BOX			
	Length (cm)	Width (cm)	Height (cm)	Weight (kg)
PXC-RP100	44	37	88	13,5
PXC-RP150	44	37	108	15,5
PXC-RP200	44	37	108	16
Part number	PALET			
	Length (cm)	Width (cm)	Height (cm)	Weight (kg)
PXC-RP100	120	100	188	12
PXC-RP150	120	100	120	6
PXC-RP200	120	100	120	6

DIMENSIONS

Part number	A (mm)	B (mm)
PXC-RP100	838	1550
PXC-RP150	1029	1930
PXC-RP200	1029	1930

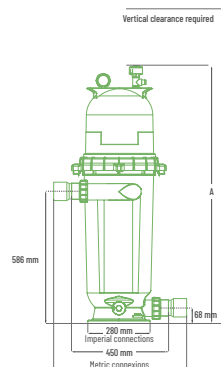

POSI-CLEAR™ RP

SYSTEM 2™



Dirt-loading capabilities up to 15 times greater than sand filters of equivalent size.

FEATURES

- ◆ Thermoplastic tank and ring withstand UV rays, heat and cold. Entire filter is corrosion resistant.
- ◆ Posi-Ring closure for easy and safe access to the cartridge for seasonal maintenance.
- ◆ Max working pressure: 3,5 bars.
- ◆ Complete media coverage combined with shallow pleats means greater dirt holding capabilities, resulting in longer filter cycles and longer period between cleanings.
- ◆ Balanced flow design utilizes the entire module area without jamming the media with debris.

TECHNICAL FEATURES & PRICE

Part number	Diameter Ø (mm)	Filter area (m ²)	Flow rate (m ³ /h)	Max pressure (bars)	Pipe connection	Clearance distance (mm)	Cartridge part number	List Price (€ excl. VAT)
PLM100	381	9,3	11,4	3,5	ID 50 - OD 63 mm	978	27002-0100S	663
PLM150	381	14,0	17,0	3,5	ID 50 - OD 63 mm	978	27002-0150S	688
PLM175	381	16,3	19,9	3,5	ID 50 - OD 63 mm	978	27002-0175S	707
PLM200	381	18,6	22,7	3,5	ID 50 - OD 63 mm	978	27002-0200S	712

Cartridges included

PACKAGING

Part number	BOX			
	Length (cm)	Width (cm)	Height (cm)	Weight (kg)
PLM100	52	52	73	17
PLM150	52	52	73	18
PLM175	52	52	73	18
PLM200	52	52	73	19
	PALET			
	115	115	160	8

DIMENSIONS

Part number	A (mm)	B (mm)
PLM100	705	978
PLM150	705	978
PLM175	705	978
PLM200	956	1448

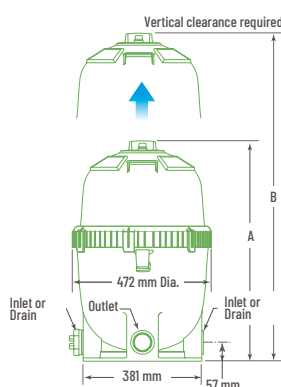

CRISTAL-FLO™ WITH FREEFLO™ OR SWIMMEY™ PUMP



A STA-RITE sand filter with a PENTAIR pump combination for aboveground pools.

FEATURES

- ◆ Cristal-Flo filter and self-priming FreeFlo or Swimmeey pump.
- ◆ Fast, easy set-up, including filter and a performance matching pump ready for installation.
- ◆ Six position top-mounted multiport valve.
- ◆ Robust single-piece base for stability.
- ◆ 50 mm swivel unions provided for quick set-up.

TECHNICAL FEATURES & PRICE

Part number		Diameter (mm)	Flow rate (m ³ /h)	Kw	HP	Valve	List Price (€ excl. VAT)	
FREEFLO™	SWIMMEY™						FREEFLO™	SWIMMEY™
PPA15-FF462	PPA15-BR462	380	5	0,25	0,375	6 way	680	721
PPA17-FF463	PPA17-BR463	430	7,4	0,375	0,5	6 way	718	760
PPA20-FF464	PPA20-BR464	500	10	0,55	0,75	6 way	786	830
PPA20-FF465	PPA20-BR465	500	10	0,75	1	6 way	801	844
PPA24-FF465	PPA24-BR465	600	14,2	075	1	6 way	850	899



CRISTAL-FLO™



FREEFLO™



SWIMMEY™



PACKAGING

Part number		BOX				PALET			
FREEFLO™	SWIMMEY™	Length (cm)	Width (cm)	Height (cm)	Weight (kg)	Length (cm)	Width (cm)	Height (cm)	Pce/Palet
PPA15-FF462	PPA15-BR462	660	495	730	23	120	80	165	4
PPA17-FF463	PPA17-BR463	685	495	795	25,5	120	80	175	4
PPA20-FF464	PPA20-BR464	715	540	845	31	120	80	185	4
PPA20-FF465	PPA20-BR465	715	540	845	31	120	80	185	4
PPA24-FF465	PPA24-BR465	650	650	1000	35	132	80	215	4

DIMENSIONS

Part number		A (mm)	B (mm)	C (mm)
FREEFLO™	SWIMMEY™			
PPA15-FF462	PPA15-BR462	760	570	650
PPA17-FF463	PPA17-BR463	920	730	675
PPA20-FF464	PPA20-BR464	960	770	710
PPA20-FF465	PPA20-BR465	1060	870	760
PPA24-FF465	PPA24-BR465	1260	1070	840

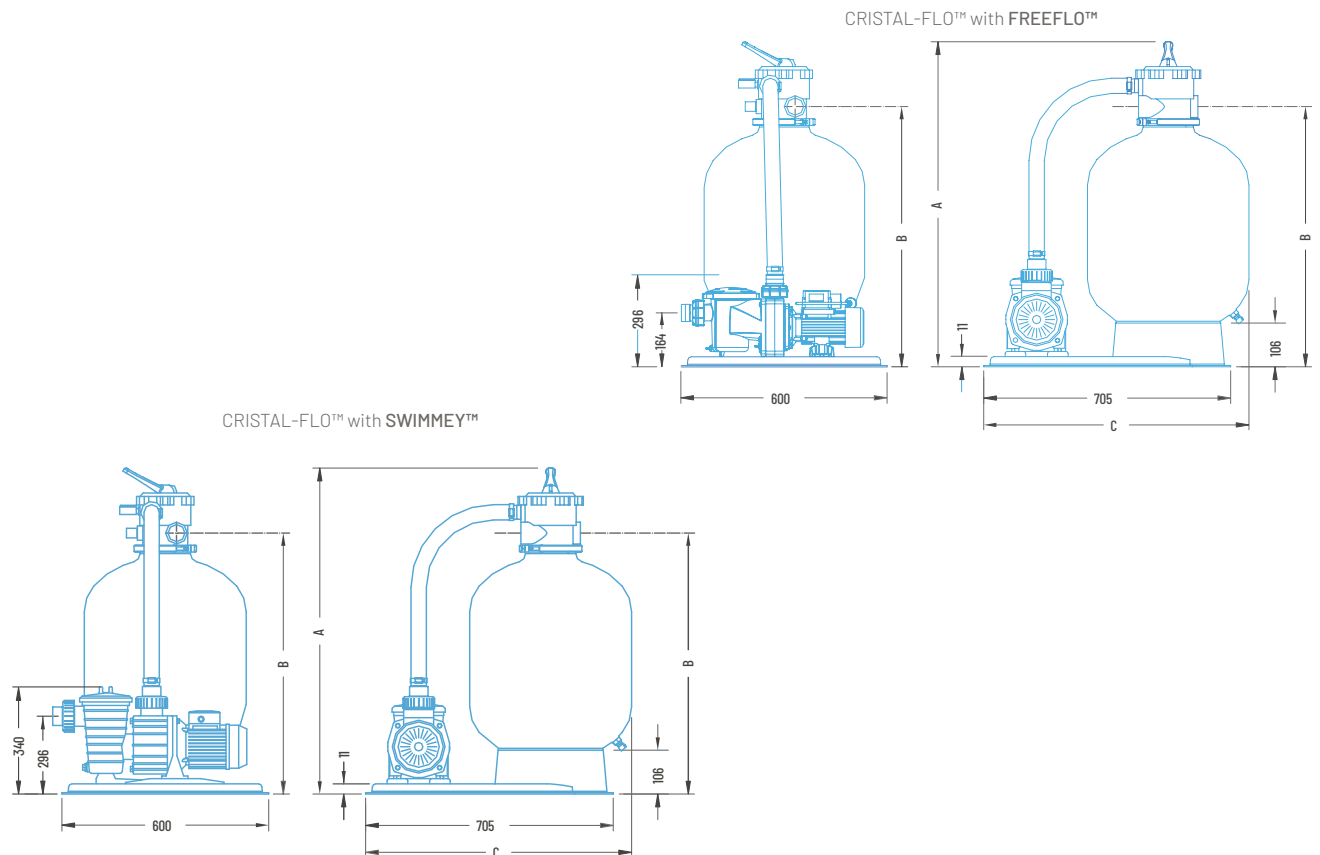

AZUR™ WITH FREEFLO™ OR SWIMMEY™ PUMP



A PENTAIR sand filter and pump combination for aboveground pools.

FEATURES

- ◆ Azur filter and self-priming FreeFlo or SwimmeY pump.
- ◆ Fast, easy set-up, including filter and a performance matching pump ready for installation.
- ◆ Six position top-mounted multiport valve.
- ◆ Robust single-piece base for stability.
- ◆ Single piece thermoplastic molded tank.
- ◆ Available with RCD (Residual Current Device)*

TECHNICAL FEATURES & PRICE

Part number		Diameter (mm)	Flow rate (m ³ /h)	Kw	HP	Valve	List Price (€ excl. VAT)	
FREEFLO™	SWIMMEY™						FREEFLO™	SWIMMEY™
	FS-12A6-SW8	300	5	0,18	0,25	6 way		494
FS-15A6-FF10	FS-15A6-SW10	375	6	0,25	0,375	6 way	503	531
FS-15A6-FF12	FS-15KT-SW12	375	6	0,375	0,5	6 way	513	538
FS-19A6-FF12	FS-19A6-SW12	475	9	0,375	0,5	6 way	556	586
FS-19A6-FF15	FS-19AZ-SW15	475	9	0,55	0,75	6 way	574	604
FS-22A6-FF15	FS-22A6-SW15	560	12	0,55	0,75	6 way	624	659
FS-22A6-FF19	FS-22AZ-SW19	560	12	0,75	1	6 way	654	685



RCD
 *(Residual Current Device)
 To order with the RCD,
 use the existing part number
 + letter R at the end.
 (i.e. FS-15A6-FF10R)

PACKAGING

Part number		BOX				PALET			
FREEFLO™	SWIMMEY™	Length (cm)	Width (cm)	Height (cm)	Weight (kg)	Length (cm)	Width (cm)	Height (cm)	Pce/Palet
	FS-12A6-SW8	650	550	350	16	120	80	166	8
FS-15A6-FF10 (R)	FS-15A6-SW10	786	600	418	16,5	120	80	180	8
FS-15A6-FF12 (R)	FS-15KT-SW12	786	600	418	20	120	80	180	8
FS-19A6-FF12 (R)	FS-19A6-SW12	815	610	580	22	120	80	190	6
FS-19A6-FF15 (R)	FS-19AZ-SW15	815	610	580	23	120	80	190	6
FS-22A6-FF15 (R)	FS-22A6-SW15	650	650	1000	27	132	80	215	4
FS-22A6-FF19 (R)	FS-22AZ-SW19	650	650	1000	30	132	80	215	4

DIMENSIONS

Part number		A (mm)	B (mm)	C (mm)
FREEFLO™	SWIMMEY™			
	FS-12A6-SW8	701	566	620
FS-15A6-FF10 (R)	FS-15A6-SW10	870	640	710
FS-15A6-FF12 (R)	FS-15KT-SW12	870	640	710
FS-19A6-FF12 (R)	FS-19A6-SW12	900	720	760
FS-19A6-FF15 (R)	FS-19AZ-SW15	900	720	760
FS-22A6-FF15 (R)	FS-22A6-SW15	1090	910	800
FS-22A6-FF19 (R)	FS-22AZ-SW19	1090	910	800

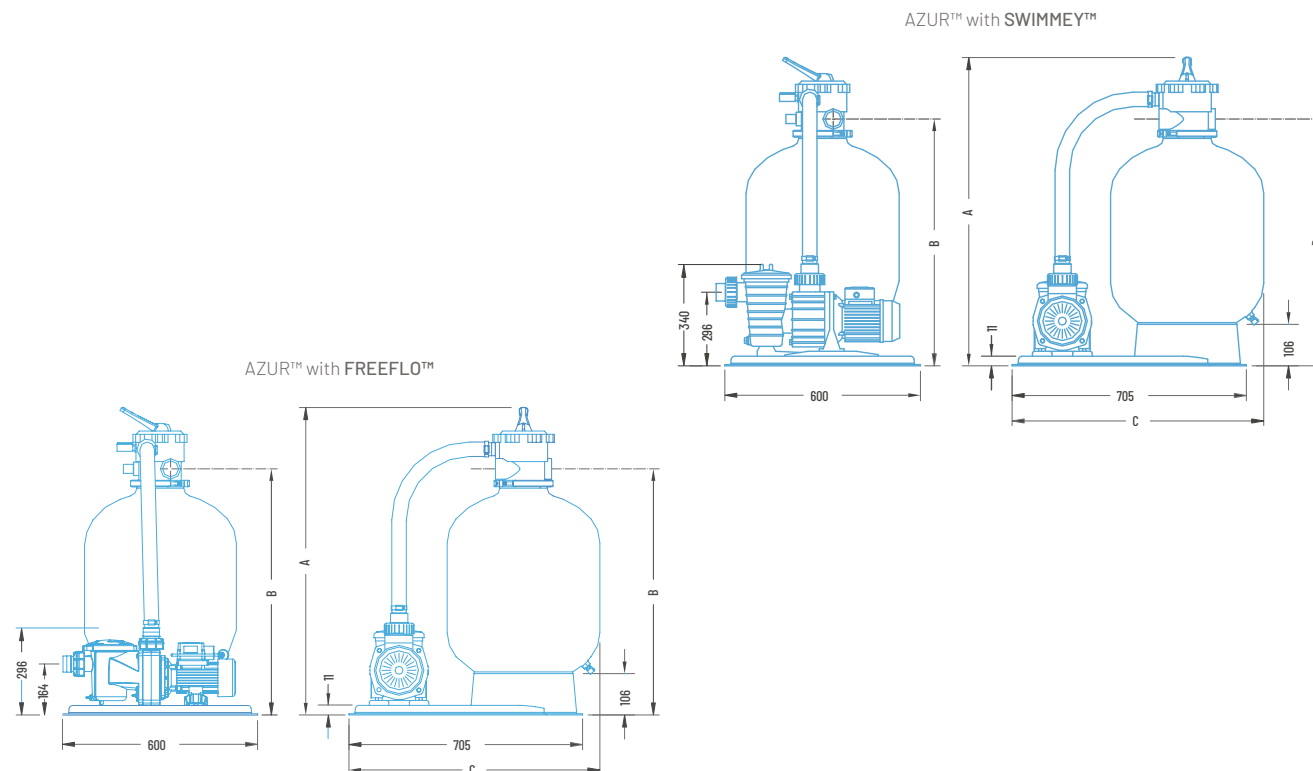

PENTAIR ACADEMY TRAINING TOUR

TAKE ONE OF PENTAIR'S LATEST TRAINING WORKSHOPS AND YOU'LL END UP WITH A WEALTH OF KNOW-HOW.



Learn about the latest developments in automation systems, pumps, heaters, lighting, filtration, water features and chlorine generation. Our experienced instructors, detailed course materials and training aids will give you the real-world techniques and understanding to specify, install, troubleshoot and service today's most advanced pool equipment... profitably. You'll certainly end up with a wealth of know-how.

Pentair products are equipped with the most recent and innovative technology and pool professionals must have an up-to-date knowledge in order to install and service them well. That's why Pentair organizes a series of workshops intended for swimming pool professionals in different locations in Europe. During these workshops, pool professionals have the opportunity to get to know our products.























The Pentair Academy Training Tour is a free training course which includes a master class, lunch and workshop material. Registration in advance is required, only a limited number of seats available. **FOR PIP MEMBERS ONLY.**

(for more info on PIP, visit www.pentairpartners.eu)

For more information, please send an email to: techsupport.poolmea@pentair.com

FILTRATION	 FILTRATION	Filtration control	
	 THERMOREGULATION	Adapts filtration duration to water temperature and pool cover position	
	 INTELLIFLO CONTROL	Smart control of IntelliFlo VSD2/VSF	
	 VARIABLE SPEED PUMP	Variable speed pump control	
	 VS UPGRADABILITY	System can be upgraded to variable speed pump control	
	 ANTI-FREEZE	Intelligent and economic anti-freeze system	
REGULATION	 BACK WASH	Backwash scheduling and control of automated backwash valves as Pentair ProValve	
	 HEATING	Control of heating system (Heat pump, Electric heater, Gas heater) with solar priority if available	
	 LIGHT CONTROL	Control of light system, selection of fixed colors and light shows of IntelliBrite color scheme	
	 LIGHT POWER SUPPLY	12V Power supply for light systems, 100W or 300W, depending of the model	
	 POOL COVER INPUT	Detect pool cover position to adapt desinfection, filtration, heating and lighting accordingly	
	 1 AUX CONTROL	1 Auxiliary output	
	 4 AUX CONTROL	Up to 6 commands/inputs and 4 devices control	
	ANALYSIS	 WATER TEMPERATURE	Display water temperature
		 SALINITY	Display Salt level in g/l (w. Salt Chlorinator) or conductivity in µS (w/o Salt Chlorinator)
	TREATMENT / DISINFECTION	 SALT CHLORINATION	Control salt chlorinator (provided separately) by ORP regulation
 INTELLICHLOR CONTROL		IntelliChlor advanced control & diagnostic	
 PH REGULATION		Adjustment of pH set point and digital display of pH value locally and remotely	
 ORP REGULATION		Adjustment of ORP set point and digital display of ORP value in mV locally and remotely	
 AMPEROMETRIC REGULATION		Adjustment of Chlorine set point and digital display of active & free chlorine rates values in mg/l (ppm) locally and remotely	
CONNECTED	 WIRELESS CONNECTIVITY	System connects wireless to the home internet router to provide remote monitoring and control anywhere, anytime from a computer, smartphone or tablet	
	 ALARMS	You are informed in real time about the condition of your pool and equipments	
	 REMOTE MAINTENANCE	Pool Professionals can remotely monitor and perform maintenance from a computer, smartphone or tablet	
	 USER PROFILES LEVEL	Different types of accounts for user, owner & professional for clear and safe operations	
PRO	 REPORTING	Automatic reporting of water quality for public pools	



 FILTRATION
 THERMOREGULATION
 INTELLIFLO CONTROL
 VS PUMP
 VS UPGRADABILITY
 ANTI-FREEZE
 BACK WASH
 HEATING
 LIGHT CONTROL
 LIGHT POWER SUPPLY
 POOL COVER INPUT
 1 AUX CONTROL
 4 AUX CONTROL
 WATER TEMPERATURE
 SALINITY
 SALT CHLORINATION
 INTELLICHLOR CONTROL
 PH REGULATION
 ORP REGULATION
 AMPEROMETRIC REGULATION
 WIRELESS CONNECTIVITY
 ALARMS
 REMOTE MAINTENANCE
 USER PROFILES LEVEL
 REPORTING

OPTIONS

	Filtration Managers	Regulation System		Automation	Connected Automation		
	SPEEDEO®	SOLEO®	SOLEO® CHLORE	SOLEO® VS	MEASTRO®	CL17®	INTELLIPOOL®
FILTRATION	✓	✓	✓	✓	✓	✓	✓
THERMOREGULATION	✓	✓	✓	✓	✓	✓	✓
INTELLIFLO CONTROL	✓	opt. ⁴	opt. ⁴	✓	opt. ¹⁺²	opt. ¹⁺²	✓
VS PUMP	✓	opt. ⁴	opt. ⁴	✓	opt. ²	opt. ²	
VS UPGRADABILITY		✓	✓		✓	✓	
ANTI-FREEZE	✓	✓	✓	✓	✓	✓	✓
BACK WASH	✓	opt. ⁴	opt. ⁴	✓	✓	✓	✓
HEATING	✓	opt. ⁴	opt. ⁴	✓	✓	✓	✓
LIGHT CONTROL	✓	opt. ⁴	opt. ⁴	✓	✓	✓	✓
LIGHT POWER SUPPLY							
POOL COVER INPUT	✓			✓	✓	✓	✓
1 AUX CONTROL					✓	✓	✓
4 AUX CONTROL					opt. ³	✓	opt. ³
WATER TEMPERATURE	✓	✓	✓	✓	✓	✓	✓
SALINITY					✓	✓	✓
SALT CHLORINATION		✓	✓	✓	✓	✓	✓
INTELLICHLOR CONTROL	✓	opt. ⁴	opt. ⁴	✓			✓
PH REGULATION		✓	✓	✓	✓	✓	✓
ORP REGULATION		✓		✓	✓		✓
AMPEROMETRIC REGULATION			✓			✓	
WIRELESS CONNECTIVITY					✓	✓	✓
ALARMS					✓	✓	✓
REMOTE MAINTENANCE					✓	✓	✓
USER PROFILES LEVEL					✓	✓	✓
REPORTING						✓	

1 - IntelliComm II needed
3 - 4X extension needed

2 - Speed FC needed
4 - Speedeo needed (delayed installation possible)

AUTOMATION & REGULATION

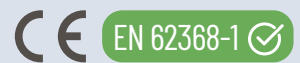

Control and automation systems

FILTRATION MANAGERS

SPEEDEO® 58

REGULATION SYSTEMS

SOLEO® 60

SOLEO® CHLORE 61

AUTOMATION SYSTEMS

SOLEO® VS 62

CONNECTED AUTOMATION SYSTEMS

MAESTRO® 64

INTELLIPOOL® 66

CL17® 68



SPEEDEO®

Control filtration, heating and lighting.

FEATURES

- ◆ IntelliFlo VSD2 and VSF Advanced Control & Diagnostic.
- ◆ Variable speed pump control.
- ◆ Backwash scheduling and control of Pentair Pro Valve automated backwash valve (provided separately).
- ◆ IntelliChlor control via bus connexion.
- ◆ Traditional heating control (PAC, electric heater) and solar heating, with solar priority.
- ◆ Replacement solution for CONTROLPRO™.
- ◆ Smart and economic anti-freezing system.
- ◆ Control the lights.
- ◆ Compatible with INTELLIBRITE®.
- ◆ Can be upgraded with the Soleo® for water quality control.

TRADEGRADE



Reference	List Price (€ VAT excl)
SB-PF-SP0-003C	514



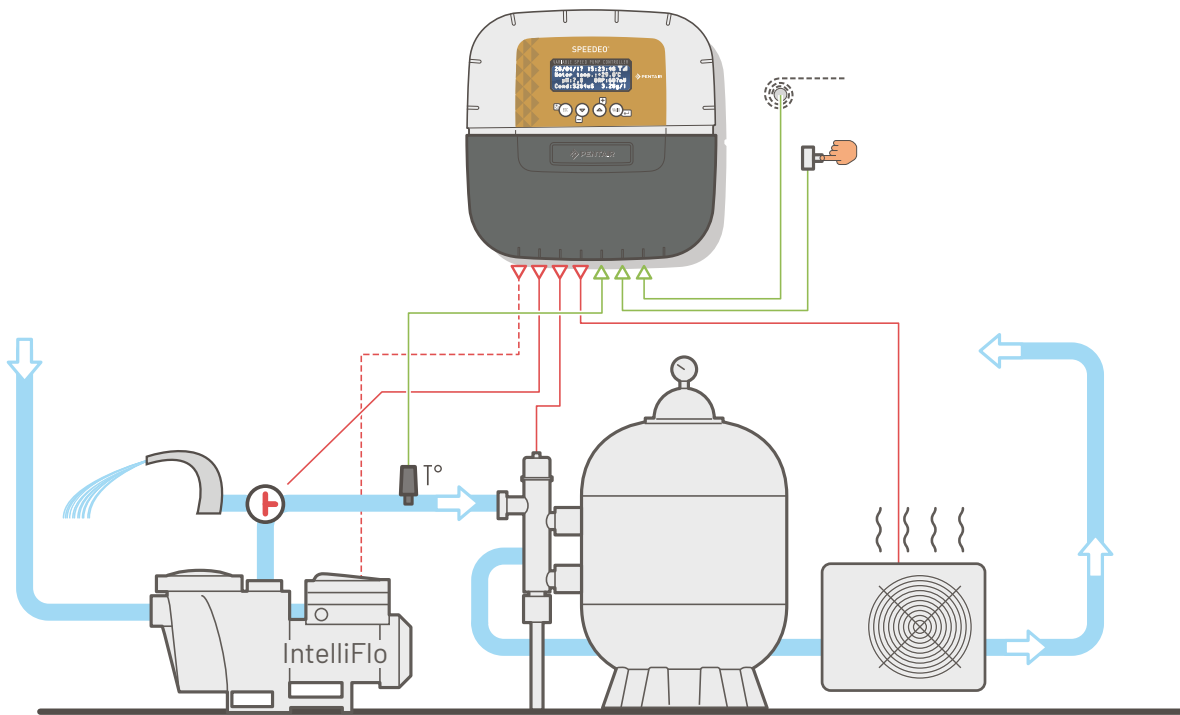

CONTENT SPEEDEO®



Speedeo
SB-PF-SP0-003B

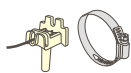

Water temp. sensor
SB-PD-PRO-004B

ACCESSORIES SPEEDEO®



Soleo
SB-PF-SOL-003B



Probe Holder Kit
INTP-HOLD-1



iChlor/SC-75
H-52-0800P
SC-75



IntelliChlor
H-52-0554C (<75 M³)
H-52-0555C (<150 M³)



SOLEO®

Water quality controller with ORP regulation.

Part Number List Price (€ VAT excl.)

SB-PF-SOL-003C

823



FEATURES

- ◆ Filtration control.
- ◆ Adapts filtration duration to water temperature.
- ◆ System can be upgraded to variable speed pump control.
- ◆ Control salt chlorinator (provided separately) by ORP regulation.
- ◆ Adjustment of pH set point and digital display of pH value locally.
- ◆ Adjustment of ORP set point and digital display of ORP value in mV locally.

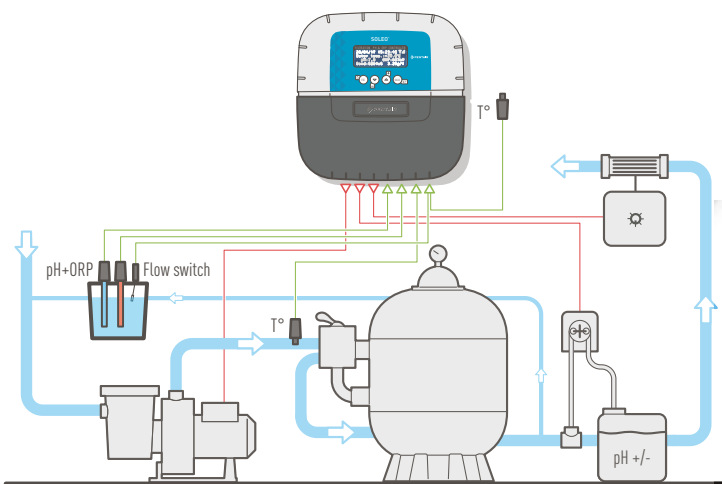

CONTENT SOLEO®



Soleo
SB-PF-SOL-003B



pH Probe & Sol pH4/pH7
INTP-5210



RedOx Probe
INTP-5220

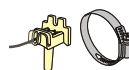

Water temp. sensor
SB-PD-PRO-004B

ACCESSORIES SOLEO®



Peristaltic dosing pump
INTP-DOS-1
more information page 74



Probe Holder Kit
INTP-HOLD-1



iChlor/SC-75
H-52-0800P
SC-75



IntelliChlor
H-52-0554C (<75 M³)
H-52-0555C (<150 M³)



Speedeo
SB-PF-SPD-003B



REGULATION SYSTEM

TRADEGRADE



SOLEO® CHLORE

Part Number List Price (€ VAT excl.)

SB-PF-SOL-004C

1004



Water quality controller with amperometric regulation.

FEATURES

- ◆ Filtration control.
- ◆ Adapts filtration duration to water temperature and pool cover position.
- ◆ System can be upgraded to variable speed pump control.
- ◆ Control salt chlorinator (provided separately) by ORP regulation.
- ◆ Adjustment of pH set point and digital display of pH value locally.
- ◆ Adjustment of Chlorine set point and digital display of active & free chlorine rates value in mg/l (ppm) locally.

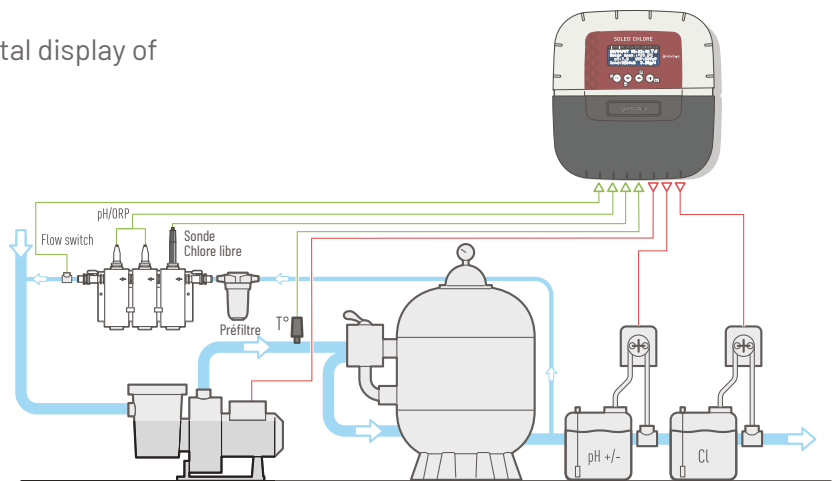

CONTENT SOLEO® CHLORE



Soleo

SB-PF-SOL-004B

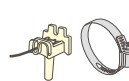

Water temp. sensor

SB-PD-PRO-004B

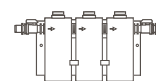

Probe chamber



Free chlorine probe



Prefilter

⚠️ ACCESSORIES NOT INCLUDED

ACCESSORIES SOLEO® CHLORE



Peristaltic dosing pump

INTP-DOS-1
more information page 74



Speedeo

SB-PF-SP0-003B





SOLEO® VS

Complete automation system with local control.

FEATURES

- ◆ IntelliFlo VSD2 & VSF Advanced Control & Diagnostic.
- ◆ Variable speed pump control.
- ◆ Backwash scheduling and control of automated backwash valves as Pentair ProValve.
- ◆ Control salt chlorinator (provided separately) by ORP regulation.
- ◆ IntelliChlor advanced control & diagnostic.
- ◆ Adjustment of pH set point and digital display of pH value locally.
- ◆ Adjustment of ORP set point and digital display of ORP value in mV locally.
- ◆ Control of heating system.



NEW

Part Number	Description	List Price(€ VAT excl.)
SB-PF-ENS-005C	SOLEO® VS	1286
SB-PF-ENS-005C-EB	SOLEO® VS + e-BOX	on demand
EB-SLVS	e-BOX pour SOLEO® VS	on demand



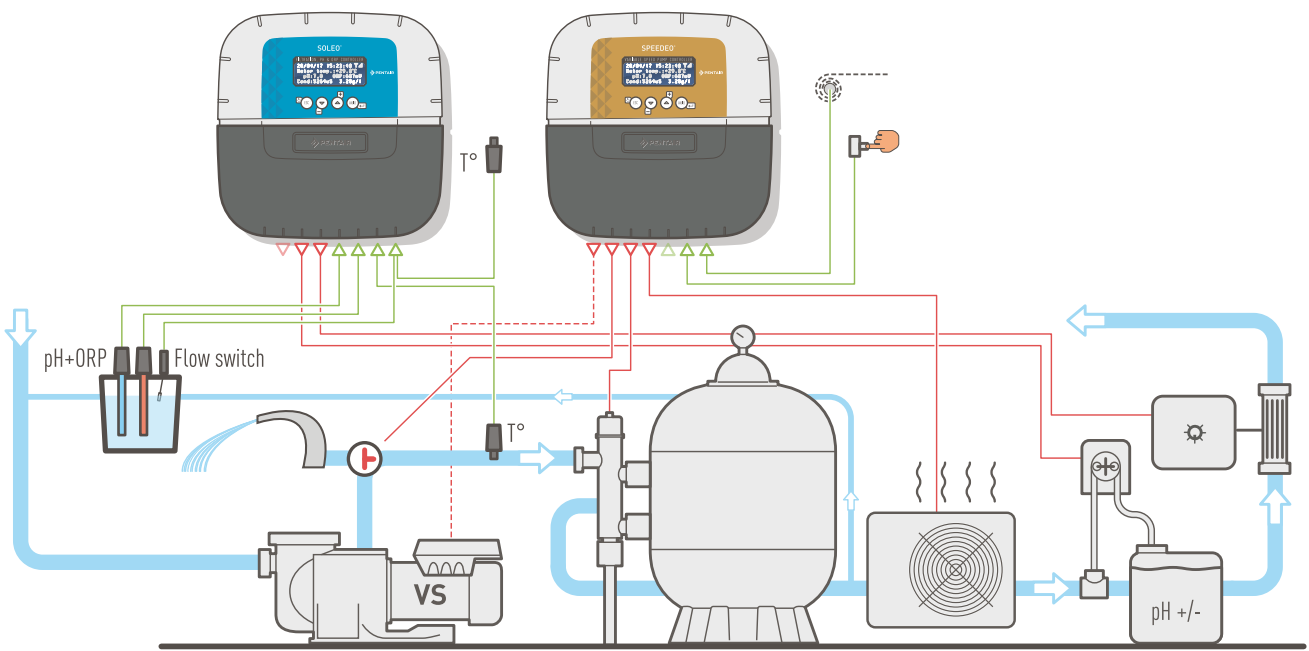

CONTENT SOLEO® VS



Soleo
SB-PF-SOL-003B



Speedeo
SB-PF-SP0-003B

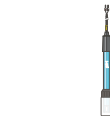

pH Probe & Sol pH4/pH7
INTP-5210



RedOx Probe
INTP-5220

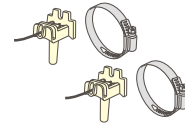

Water temp. sensor
SB-PD-PRO-004B

ACCESSORIES SOLEO® VS



Peristaltic dosing pump
INTP-DOS-1
more information page 74



Probe Holder Kit
INTP-HOLD-1



iChlor/SC-75
H-52-0800P
SC-75



IntelliChlor
H-52-0554C (<75 M³)
H-52-0555C (<150 M³)

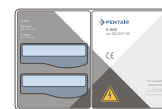

e-BOX
EB-SLVS



MAESTRO®

Complete & CONNECTED automation system with remote control.

FEATURES

- ◆ Filtration, water temperature and light control.
- ◆ Control salt chlorinator or dosing pump (provided separately) by ORP regulation and digital display of ORP value locally and remotely.
- ◆ Adjustment of pH set point and digital display of pH value locally and remotely.
- ◆ Upgradable system for variable speed pumps control.
- ◆ System connects wireless to the home internet router to provide remote monitoring and control anywhere, anytime from a computer, smartphone or tablet (not included).
- ◆ You are informed in real time about the condition of your pool and equipments.
- ◆ Pool Professionals can remotely monitor and perform maintenance from a computer, smartphone or tablet.



Part Number	Description	List Price (€ VAT excl.)
SB-PF-ENS-002D	MAESTRO®	2 213
SB-PF-ENS-002D-EBL	MAESTRO® + e-BOX LITE	sur demande
SB-PF-ENS-002D-EB	MAESTRO® + e-BOX ⁽¹⁾	sur demande
EB-MSTR-L	e-BOX LITE pour MAESTRO®	sur demande
EB-MSTR	e-BOX ⁽¹⁾ pour MAESTRO®	sur demande

⁽¹⁾ Speed FC & 4X Extension included

NEW



Tablet not included

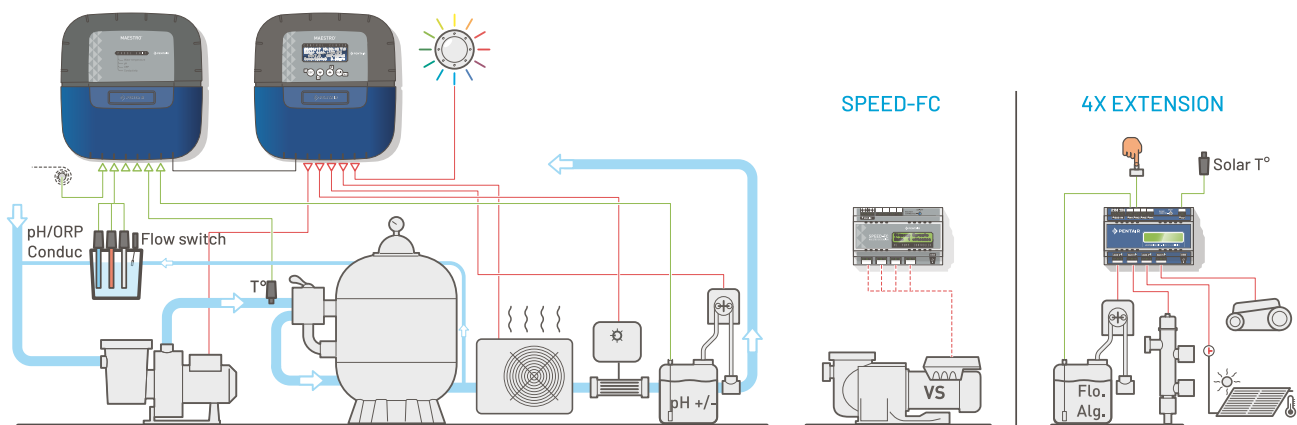

CONTENT MAESTRO®



Probe Unit
SB-PF-PRO-004C



Control Center
SB-PF-TEC-002B



Indoor Display
SB-PF-DOM-001A



Radio Relay
SB-PF-PER-001C

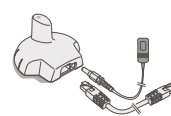

Internet Hub
INTP-5164



pH Probe & Sol pH4/pH7
INTP-5210



RedOx Probe
INTP-5220



Conductivity Probe
INTP-5230

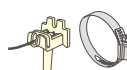

Water temp. sensor
SB-PD-PRO-004B

ACCESSORIES MAESTRO®



Peristaltic dosing pump
INTP-DOS-1
more information
page 74



Probe Holder Kit
INTP-HOLD-1



iChlor/SC-75
H-52-0800P
SC-75



IntelliChlor
H-52-1208Cl (<55m²)
H-52-0554C (<75M²)



Speed FC
SB-PF-INA-003C



IntelliComm II
521109-EU



4X Extension
INTP-1030B



e-BOX
SB-PF-ENS-002D-EBL
SB-PF-ENS-002D-EB



INTELLIPOOL®

Complete & CONNECTED automation system with remote control for Pentair Intelli products.

FEATURES

- ◆ IntelliFlo VSD2 & VSF Advanced Control & Diagnostic.
- ◆ Control salt chlorinator (provided separately) by ORP regulation.
- ◆ IntelliChlor advanced control & diagnostic.
- ◆ Adjustment of pH set point and digital display of pH value locally and remotely.
- ◆ Adjustment of ORP set point and digital display of ORP value in mV locally and remotely.
- ◆ Ultratemp heat pump control (separately provided).
- ◆ System connects wireless to the home internet router to provide remote monitoring and control anywhere, anytime from a computer, smart-phone or tablet (not included).
- ◆ You are informed in real time about the condition of your pool and equipments
- ◆ Pool Professionals can remotely monitor and perform maintenance from a computer, smart-phone or tablet.



NEW

Référence	Description	Prix Liste (€HT)
INTP-1010-B	INTELLIPOOL®	3899
INTP-1010B-EBL	INTELLIPOOL® + e-BOX LITE	sur demande
INTP-1010B-EB	INTELLIPOOL® + e-BOX ⁽¹⁾	sur demande
EB-INTP-L	e-BOX LITE pour INTELLIPOOL®	sur demande
EB-INTP	e-BOX ⁽¹⁾ pour INTELLIPOOL®	sur demande

⁽¹⁾ 4X Extension included



Tablet not included

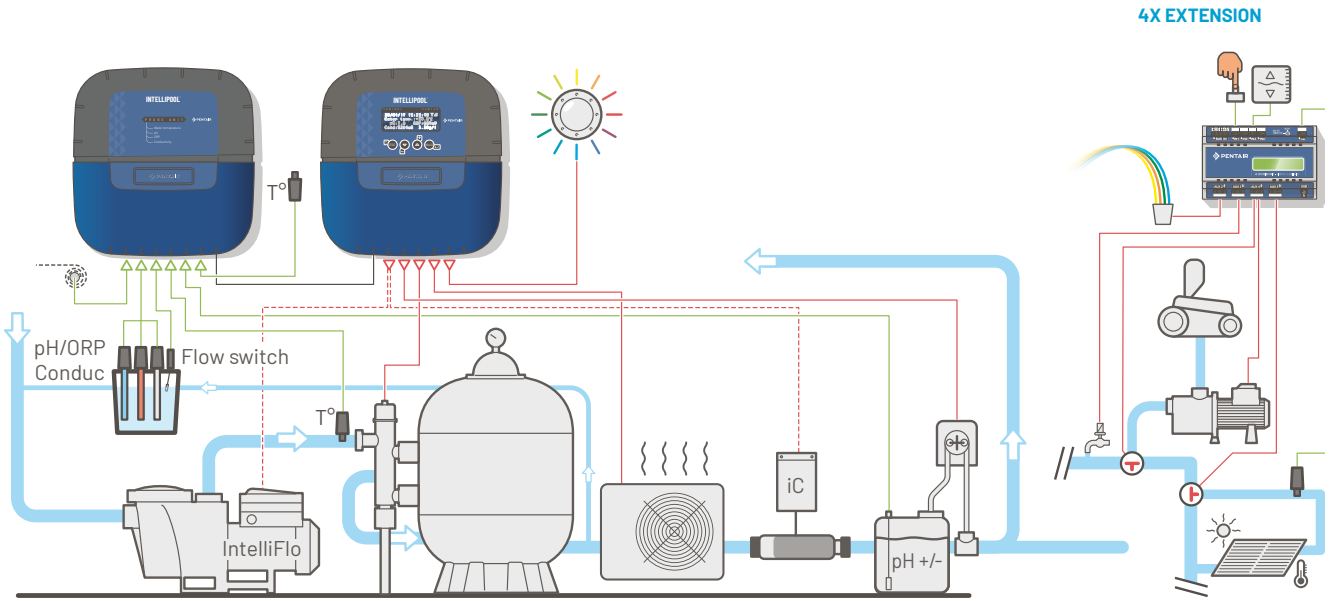

CONTENT INTELLIPOOL®



Probe Unit
SB-PF-PRO-004C



Control Center
INTP-5163



Indoor Display
INTP-5160



Radio Relay
INTP-5150

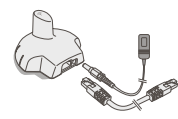

Internet Hub
INTP-5164

CONTENT INTELLIPOOL®



pH Probe & Sol pH4/pH7
INTP-5210



RedOx Probe
INTP-5220



Conductivity Probe
INTP-5230

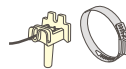

Water temp. sensor
H-52-0272

ACCESSORIES INTELLIPOOL®



Peristaltic dosing pump
INTP-DOS-1
plus d'informations
page 74



Probe Holder Kit
INTP-HOLD-1



UltraTemp®-HX
UTHP-9-HX-R32
UTHP-12-HX-R32
UTHP-15-HX-R32
UTHP-17-HX-R32



IntelliChlor
H-52-0554C (<75 M³)
H-52-0555C (<150 M³)



4X Extension
INTP-1030B



INTELLIFLO® VSF & VSD2
WFL-VSF
5PXF-VSF
UFL-VSD2
SW5P6R-VSD2



iChlor/SC-75
H-52-0800P
SC-75



e-BOX
INTP-1010B-EBL
INTP-1010B-EB



CL17®

Complete & Connected Automation System with amperometric regulation.

FEATURES

- ◆ Filtration, water temperature and light control.
- ◆ Adjustment of pH set point and digital display of pH value locally and remotely.
- ◆ Adjustment of Chlorine set point and digital display of active & free chlorine rates value in mg/l (ppm) locally and remotely.
- ◆ System connects wireless to the home internet router to provide remote monitoring and control anywhere, anytime from a computer, smartphone or tablet (not included).
- ◆ You are informed in real time about the condition of your pool and equipments.
- ◆ Pool Professionals can remotely monitor and perform maintenance from a computer, smartphone or tablet (not included).
- ◆ Automatic reporting of water quality for public pools.
- ◆ Upgradable system for variable speed pumps control.



Part Number	Liste Prix (€ VAT excl.)
SP-PF-CL1-001C	3681



Tablet not included

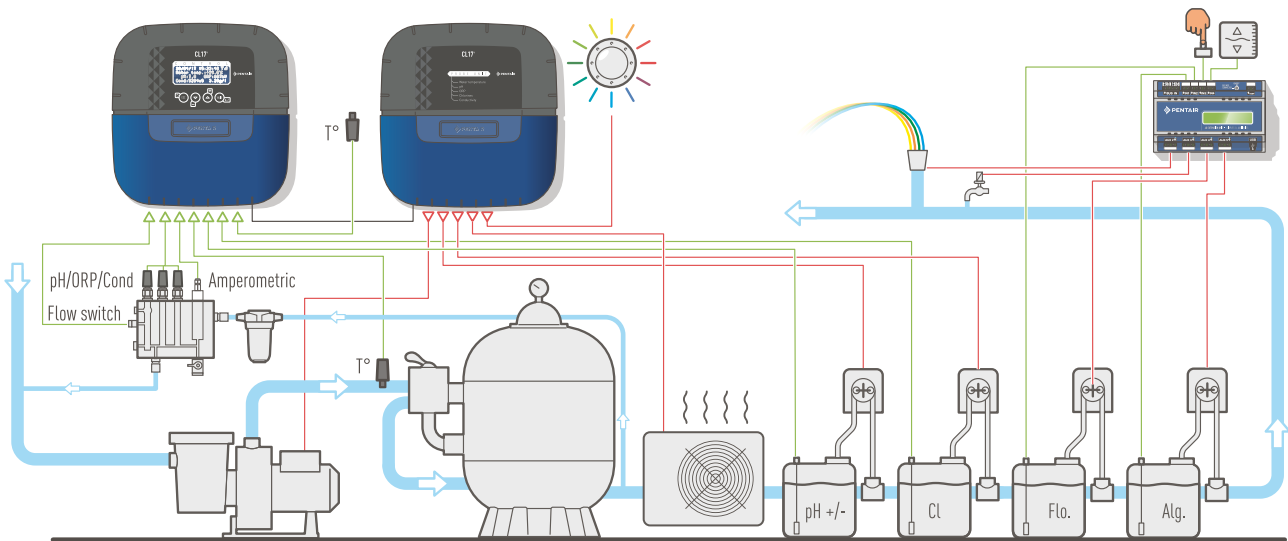

CONTENT CL17®



Probe Unit
SP-PF-PRO-001A



Control Center
SP-PF-TEC-001A



4X Extension
INTP-1030B



Radio Relay
INTP-5150

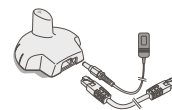

Internet Hub
INTP-5164



pH Probe & Sol pH4/pH7
SP-PD-DIV-002A



RedOx Probe
INTP-5220



Conductivity Probe
INTP-5230

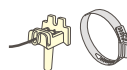

Water temp. sensor
SB-PD-PRO-004B

ACCESSORIES CL17®



Peristaltic dosing pump
INTP-DOS-1
more information page 74



Speed FC
SB-PF-INA-003C



IntelliComm II
521109-EU

 ACCESSORIES NOT INCLUDED

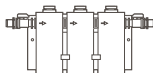

Probe chamber



Free chlorine probe



Prefilter

WATER TREATMENT

SALT CHLORINATOR

ICHLOR® / SC-75™72
INTELLICHLOR®73

DOSING & MEASURING

PENTAIR PERISTALTIC DOSING PUMP74
PROBE HOLDER.....74

CHLORINE FEEDER

BY-PASS CHLORINE FEEDER.....75
IN-LINE CHLORINE FEEDER.....75
COMMERCIAL CHLORINE FEEDER.....75



SC-75™ / iCHLOR™

Compact salt chlorinator.



TRADEGRADE

SC-75

FEATURES

- ◆ Compact design, fits most small technical rooms.
- ◆ For above ground and small inground pools up to 90 m³.
- ◆ Polarity switching makes it self-cleaning and suitable for high calcium areas.
- ◆ 6.000 hour blade life.
- ◆ Vertically or horizontally mounting.
- ◆ Easy-to-view displays for fast checking of salt levels, cell cleanliness, sanitizer output and water flow.
- ◆ Chloring adjustment according to 3 levels is as easy as pressing two buttons.
- ◆ Integrated sensors to ensure adequate water flow for safer chlorine generation.
- ◆ For residential pools only. For commercial pools, please contact your local Pentair representative.
- ◆ Minimum flow 5,7 m³/h.

TECHNICAL FEATURES & PRICE

Part Number	Description	Pool size (m ³)	Chlorine / day (g)	Life hours (h)	PIP points	List Price (€ VAT excl)
SC-75	STA-RITE salt chlorinator (SC-75)	90	500	6.000	(75)+ 25	773
H-52-0800P	PENTAIR salt chlorinator (iCHLOR)	90	500	6.000	75	792

DIMENSIONS

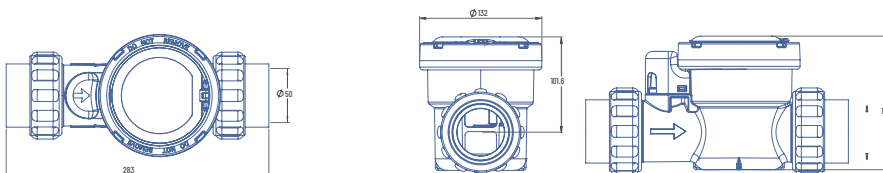

CONTENT iCHLOR™ AND SC-75™



Union set

R520814



Cell

H-52-0801 → (iCHLOR™)
Y-1146 → (SC-75™)



Plastic power cabinet

H-52-0802P → (iCHLOR™)
SC-75P → (SC-75™)



iCHLOR

INTELLICHLOR®

Smart salt chlorinator.



FEATURES

- ◆ A standard in chlorine generator technology to keep water sparkling clean where salt will be turned into chlorine.
- ◆ All controls and displays directly built into the cell.
- ◆ Chlorine adjustment according 10 levels is as easy as pressing two buttons.
- ◆ Automatic shut-off feature protects the unit and extends cell life under low water temperature conditions.
- ◆ On-time cycling prevents calcium and scale build-up to maximize cell life.
- ◆ Full diagnostic capabilities thanks to the IntelliChlor diagnostic wand.
- ◆ IC20 and IC40 are compatible with IntelliPool & Soleo VS.
- ◆ For residential pools only. For commercial pools, please contact your local Pentair representative.
- ◆ Minimum flow 5 m³/h.

TECHNICAL FEATURES & PRICE

Part Number	Description	Pool size (m ³)	Chlorine / day (g)	Life hours (h)	List Price (€ VAT excl)
H-52-0554C	IntelliChlor IC20, including powercenter and cell	75	320	10.000	1668
H-52-0555C	IntelliChlor IC40, including powercenter and cell	150	640	10.000	1965

DIMENSIONS

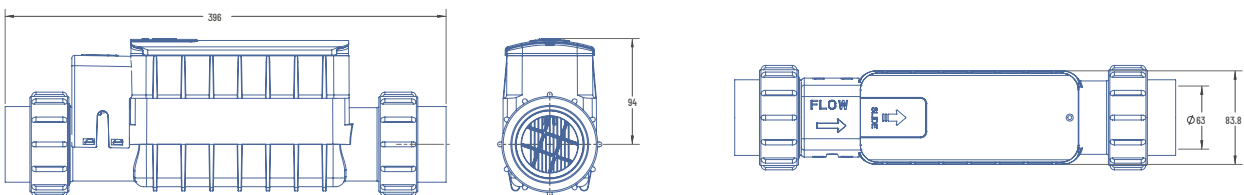

CONTENT INTELLICHLOR®

ACCESSORIES INTELLICHLOR®



Union kit
H-52-0595



Cell
H-52-0881 → (IC20)
H-52-0802 → (IC40)



Power cabinet
H-52-0883



Acid washing kit
520670



Spacer cell
H-52-0884



IntelliChlor diagnostic wand
H-52-0594



PERISTALTIC DOSING PUMP

FEATURES

- ◆ Peristaltic dosing pump with level sensor for the chemical tank.
- ◆ Flow: 1,5 l / 1,5 bar / h.
- ◆ To be used to control pH +/- or chlorine.
- ◆ Ideal extension/optimization of IntelliPool, Maestro and Soleo automation systems.
- ◆ Saves energy by operating at low speed.
- ◆ Delivered in bundle pack: dosing pump / suction plunger with level sensor and suction tube / injection valve / wall mounting bracket / stickers for marking pH+, pH- or Cl / spare membrane hose.

Part Number	Description	List Price (€ VAT excl.)
INTP-DOS-1	Peristaltic dosing pump KIT	363



Suction lance with level sensor integrated

PROBE HOLDER

Ideal accessory for an easy probes installation (pH, RedOx and ORP) of automation and regulation systems.

FEATURES

- ◆ Supports 3 probes
- ◆ Large transparent chamber that makes it possible to check the flow and condition of the water
- ◆ 4 m long transparent pipe
- ◆ Saddle clamps and valves for an installation on pipes.
- ◆ Back plate holder for fixing to the wall

Part Number	Description	List Price (€ VAT excl.)
INTP-HOLD-1	Probe holder	356



BY-PASS FEEDER

Part Number	Description	Pces/box	List Price (€ VAT excl.)
H-RAK171016EC (# 300C)	Transparent chlorine feeder	6	146



H-RAK171016EC (# 300C)

IN-LINE FEEDER

Part Number	Description	Pces/box	List Price (€ VAT excl.)
H-RAK171096EC (# 320C)	Transparent chlorine feeder	6	153



H-RAK171096EC (# 320C)

COMMERCIAL FEEDER

Part Number	Description	Pces/box	List Price (€ VAT excl.)
H-RA-171215E	Feeder capacity : 6,8 kg	1	294
H-RA-171230E	Feeder capacity : 13,6 kg	1	319
H-RA-171240E	Feeder capacity : 18 kg	1	332



H-RA-171215E
6,8 kg

H-RA-171230E
13,6 kg

H-RA-171240E
18 kg

WHAT POOL CLEANER DO YOU NEED?

Cleaning is an essential task of the pool maintenance and automatic pool cleaners make it much easier for pool owners. There are many types of automatic cleaners and the choice depends on the type of pool: shape and size, surroundings, finish, etc. but also on the pool usage and pool-owner budget.

SUCTION-SIDE CLEANER

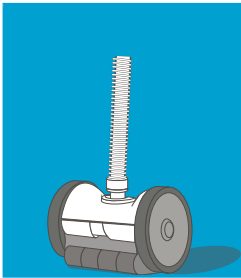

Vacuum cleaners or hydraulic cleaners are designed to plug into the vacuum inlet or skimmer of the pool and use the suction power of the filtration pumps. The pump allows the cleaner to move and swallow debris at the bottom of the pool (or eventually on walls) to the main filtration system. This type of cleaner requires a regular cleaning of the pump basket and filter.

Affordable, easy to install and use, it requires the filtration pump to operate and frequent filter backwashing.

PRESSURE-SIDE CLEANER

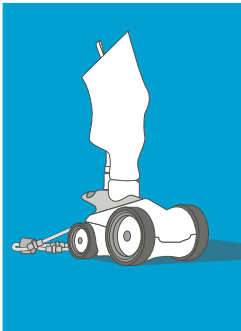

Pressure-side cleaners benefit from a dedicated hydraulic system with a booster pump. They plug into an outlet fitting or a dedicated outlet connected to a booster pump. Using the pressure of water, the cleaner is able to move, swallow debris to its own filtration bag or push them up with its sweep tail so they get sucked by the main filtration. BlueFury GT is the only pressure-side cleaner with a scrub brush for active cleaning.

High performing and robust, pressure-side cleaners remain a good compromise and the most affordable replacement option for pool equipped with a booster pump.

ELECTRIC CLEANER

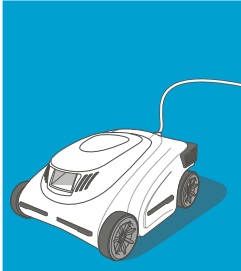

Electric cleaner or Robotic cleaner are the most advanced cleaners. Completely autonomous, they don't require any other equipment to operate. "Smart" or equipped with navigation systems, most of them they are able to adapt their path to optimize pool coverage or avoid obstacles. They offer different modes and cycle times to adapt to pool owner's needs.

Autonomous, performing in any condition and equipped with smart technologies, this is currently the most popular type of cleaner.

SWIMMING POOL CLEANERS

Suction-side, Pressure-side and Electric

SUCTION-SIDE CLEANERS

- 'LIL SHARK™78
- SANDSHARK™78
- BLUEREBEL™79
- LIL' REBEL™79

PRESSURE-SIDE CLEANERS

- BLUEFURY® LITE..... 80
- BLUEFURY® GT 81

ELECTRIC CLEANER

- BLUESTORM® 82



'LIL SHARK™



Ideal for above-ground and small swimming pools.
Convenient and easy to use.

FEATURES

- ◆ New lovely design.
- ◆ Scrubs pool floor with its patented bristles.
- ◆ 2-way cleaning removes even the toughest dirt.
- ◆ Suction cleaning as from 6 m³/h.
- ◆ Includes adaptor piece to hook up the cleaner to a telescopic pole for the hard to reach areas.



Part number	Pce/Palet	Liste Price (€ VAT excl.)
360100-EU	20	322

SANDSHARK™



Easy to use and for all type of swimming pools.

FEATURES

- ◆ Exclusive SmartTrac steering system moves the cleaner to every corner of the pool.
- ◆ 2-way cleaning, scrubs the pool floor using its rubber fins, sucks up the dirt into the filtration system.
- ◆ Suction cleaning as from 10 m³/h.
- ◆ Includes patented flow gauge and regulator valve, making it possible to adjust the flow optimally.



Part number	Pce/Palet	Liste Price (€ VAT excl.)
GW7900E	20	477

BLUEREBEL™



Even more efficient, nothing can resist him. Easy to install, suit for all types of pools.

FEATURES

- ◆ Excellent performance with variable speed pumps at low flow rates for super efficient operation.
- ◆ Two wheel design for outstanding manoeuvrability in tight spaces.
- ◆ Climbs 90° angles, cleans up to the water line.
- ◆ Programmed steering assures complete, thorough cleaning coverage.
- ◆ Exceptional Sure-Flow turbine design allows dirt and debris to easily pass through BlueRebel, unlike competing models.
- ◆ Suction cleaning as from 8 m³/h.



Turbine "Sure-Flow"

Part number	Pce/Palet	Liste Price (€ VAT excl.)
360275-EU	33	452

LIL' REBEL™



Superior manoeuvrability and cleaning for aboveground pools.

FEATURES

- ◆ Specially designed for above-ground pools.
- ◆ Two wheels conception.
- ◆ Assured manoeuvrability with its swivel connector.
- ◆ Exceptional turbin Sure-Flow design allows dirt and debris to easily pass through the cleaner, without sealing.
- ◆ Suction cleaning as from 6 m³/h.



Part number	Pce/Palet	Liste Price (€ VAT excl.)
360450-EU	20	262

BLUEFURY® GT

BLUEFURY® LITE

The cleaners that push the limits of performance & design.

FEATURES

- ◆ Available in entry-level version "Lite" and premium "GT".
- ◆ 4 ventury jets create maximum vacuum power.
- ◆ 40% larger intake inhales dirt and debris of all sizes and shapes.
- ◆ Quick and easy Snap-on debris bag.
- ◆ Includes a patented flow gauge to set cleaner speed.

Available only with BlueFury GT

- ◆ Cleans continuously in forward and reverse modes for complete and uninterrupted coverage.
- ◆ Front rotating brush scrubs and scours for a deep and detailed clean.
- ◆ "Night Cruize™" LED included .

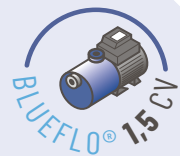

BLUEFURY® GT
360271-EU

Model	Part	Pce/Palet	Liste Price (€ VAT excl.)
BLUEFURY® GT	360271-EU	16	955



Night Cruize™



Rotating brush

Features	BlueFury GT	BlueFury Lite
Rotating Brush	YES	NO
LED "NIGHT CRUIZE"	YES	NO
Backup valve	Internal	External
Suction during backup	YES	NO
Booster requirement	BlueFlo 1,5 HP	BlueFlo 1 HP
RPM	33-36	40
Pool type	All except tiles	All

Model	Part number	Pce/Palet	Liste Price (€ VAT excl.)
BLUEFURY® LITE	360435	16	698

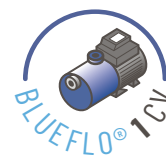

BLUEFURY® LITE
360435

TRADEGRADE



BLUESTORM®

The innovation for efficient and easy pool cleaning.

FEATURES

- ◆ Multi-JetNav - Patented motion system combining linear moves and rotations for smart grid cleaning and optimal pool coverage.
- ◆ Sense'n'Go - Patented system with automatic path optimization based on obstacle detection.
- ◆ Work also in cold water (down to 1°C).
- ◆ Floor cleaning of above-ground or in-ground pools.
- ◆ Pools up to 10 x 5m.
- ◆ All shapes.
- ◆ Flat pool bottom or gentle slopes.
- ◆ All type of coating.
- ◆ Delivered with two filters of 40 and 25 microns.

Part number	Pce/Palet	Liste Price (€ VAT excl.)
BSTR-1010	8	720



Multi-JetNav

Patented motion system combining linear moves and on-the-spot rotations for smart grid cleaning and optimal pool coverage.



Sense'n'Go

Patented system with automatic route optimization based on obstacle detection. Adapts to all pool shapes, does not stop moving



ELECTRIC CLEANER



Works all year, also in cold water down to 1° C.



Hassle-free: a high resistance motor, no brushes, no gears, no belts.



Maintenance is straightforward and affordable.



12-meter-long cable.



Call our hotline: +33 9 51 53 95 64. Replacement available within 72 hours. (open days)



Lightweight (only 6 kg).



Gentle cleaning with no damage, guaranteed not to leave marks, scratches or wear away the liner.



Night Cruize™ - a bluish lightbeam illuminates the pool during nighttime clean.



External timer mode - connect the control unit with a timer and schedule your daily cleaning cycle.



Easy-to-clean, high capacity, transparent debris canister with removable filter bag.

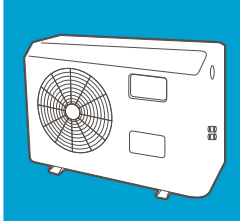

WHAT HEATING SYSTEM DO I NEED?**HEAT PUMP**

Needless to demonstrate the benefits of Heat-pump, best proof is that it has almost replaced any other heating method in Europe. With COP around 5 so 5kW of heat for each kW of energy absorbed, Heat-pump allows to maintain pool water at a constant level which makes it, in a regular use context, the most economic way to extend your pool season.

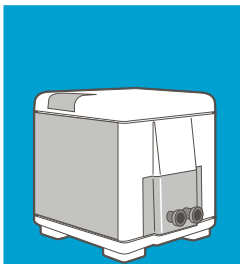
GAS HEATER

Gas heater technology has evolved a lot and their efficiency has improved dramatically. So it is for pool heaters including best-in class Pentair MasterTemp, to such extend that depending the usage, it can be a more economic alternative to Heat-pump.

HOW COME?

Whatever how often you use your pool, because of Heat-pump's long inertia you need to constantly maintain water to the desired temperature otherwise you may end up in the cold when you want to swim. Moreover, Heat-pump performances decrease as the temperature goes down therefore it needs to run even longer to maintain the desired temperature.

With MasterTemp, you only heat-up your pool when you planned to use it. Less than 8 hours are required to heat-up a 48m³ pool from 15°C to 26°C*. And when you do not plan to swim, it costs you nothing.

With the current cost of gas and electricity in EU when you use your pool no more than two week-ends per month, a MasterTemp will cost 5% less energy than a heat-pump.

Example of a month of June in the center of France (Average ambient temperature: 15°C) :

- ◆ Heat-pump monthly energy consumption : **100€**
- ◆ MasterTemp gas heater monthly energy consumption : **95€***

MOREOVER :

- ◆ A MasterTemp costs significantly less than Heat pump at equivalent power range.
- ◆ A MasterTemp can be installed inside even on a wooden floor, no ugly heat-pump in your backyard or fan noise.
- ◆ Heat-pump will run from 300 to 500 hrs/month while MasterTemp gas heater only needs 20 hours of functioning for two week-ends of heated water.
- ◆ **Less noise, less wear on heater and filtration equipment, lower maintenance cost and longer life span.**
- ◆ 15°C water requires much less filtration and chemistry.

EXAMPLE OF APPLICATIONS WHERE MASTERTEMP GAS HEATER IS THE WISE CHOICE:

- ◆ Holiday house, rental house (turn on gas heater at your arrival Friday evening and swim in heated water Saturday morning).
- ◆ Early / late season.
- ◆ Spa.

* with a MasterTemp 300

SWIMMING POOL HEATING

Heat pump & Gas heater

HEAT PUMP

ULTRATEMP®-E..... 86

ULTRATEMP®-HX..... 88

GAS HEATER

MASTERTEMP®..... 90



ULTRATEMP®-E



Constant and permanent heating, the most economic way to heat your swimming pool.

FEATURES

- ◆ Easy to use, multi language LCD control board.
- ◆ 100% pure titanium heat exchanger assures corrosion-free performance for extra-long life.
- ◆ Active defrost feature senses refrigerant temperature and prevents freezing, allowing the heat pump to operate at temperatures as low as 10°C.
- ◆ Pool/Spa function enables easy dual temperature control.
- ◆ Compatible with IntelliPool® automation system enabling remote operation, diagnosis and alarm status.
- ◆ Long-life corrosion resistant plastic panels.
- ◆ Daikin® Scroll Compressor on UltraTemp®- E 15.
- ◆ Performance and efficiency tested by TUV.
- ◆ AutoSet (time clock over-ride) feature monitors water temperature and can the water circulation pump on and off as needed to maintain desired pool temperatures.
- ◆ R 410 A refrigerant.
- ◆ Corrosion resistant "blue fin" evaporator.
- ◆ Titanium heat exchanger : 10 years warranty.



TECHNICAL FEATURES

Part Number	Model	Heating power				Min. Flow (m ³ / h)	Breaker size (amp.)	Volt (v)	Phase	List Price (€ VAT excl.)
		air 26° / water 26°*		air 15° / water 26°*						
		kW	COP	kW	COP					
460990	UltraTemp-E 8	8,5	5,2	7,2	4,7	4	16	220-240	1~	2588
460991	UltraTemp-E 10	10,6	5,1	9,1	4,8	5	16	220-240	1~	3365
460992	UltraTemp-E 12	13,0	5,3	11,3	4,9	5	20	220-240	1~	4023
460993	UltraTemp-E 15	16,1	5,2	14,5	4,8	5	25	220-240	1~	4753

* NF414 compliant

DIMENSIONS

Part Number	Model	A (mm)	B (mm)	C (mm)	D (mm)	E (mm)	F (mm)	G (mm)	Net Weight (kg)
460990	UltraTemp-E 8	632	1006	352	650	372	300	111	57
460991	UltraTemp-E 10	632	1006	352	650	372	300	111	70
460992	UltraTemp-E 12	762	1025	413	640	422	420	106	90
460993	UltraTemp-E 15	762	1025	413	640	422	420	106	115

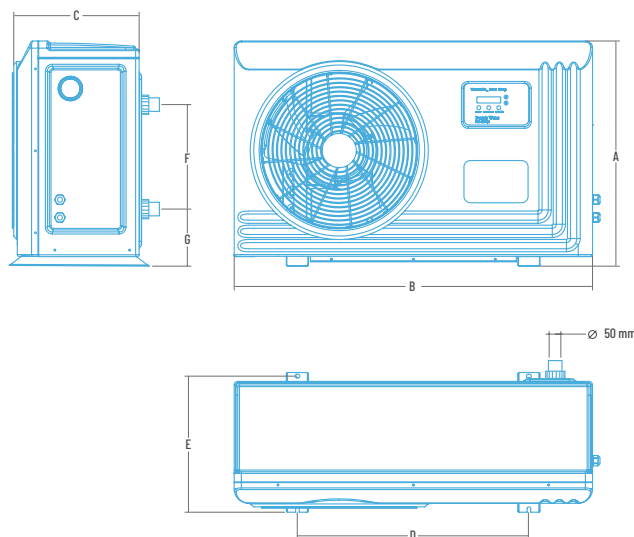

PACKAGING

Part Number	Model	Palet LxBxH	Pce /Palet	Gross Weight (kg)
460990	UltraTemp-E 8	1120x420x760	1	67
460991	UltraTemp-E 10	1120x420x760	1	80
460992	UltraTemp-E 12	1140x490x885	1	105
460993	UltraTemp-E 15	1140x490x885	1	130



+33 4 37 20 04 05

ULTRATEMP®-HX

Silent, efficient and reliable.

FEATURES

- ◆ HReversible: Heats & Cools.
- ◆ Backlit LCD display with intuitive user interface.
- ◆ 100% pure titanium heat exchanger assures corrosion-free performance for extra-long life (15-year warranty).
- ◆ Active defrost feature senses refrigerant temperature and prevents freezing, allowing the heat pump to operate at temperatures as low as -10°C.
- ◆ High Efficiency - With a COP as high as 5.48 the UltraTemp offers over five times more heat power than electrical power input. Giving you exceptional performance at the lowest running cost.
- ◆ Long-life corrosion resistant plastic panels.
- ◆ Performance and efficiency tested by TUV.
- ◆ AutoSet (time clock over-ride) feature monitors water temperature and can the water circulation pump on and off as needed to maintain desired pool temperatures.
- ◆ R32 eco-friendly gas refrigerant.
- ◆ Anti-corrosion hydrophilic evaporator coating.
- ◆ Extremely silent : 29dB(A)@10 m.
- ◆ Embedded Wi-Fi module and smartphone control.



Pilot your UltraTemp®-HX with Smart Life App.



TECHNICAL FEATURES

Part Number	Model	Heating power				Min. Flow (m ³ / h)	Breaker size (amp.)	Volt (v)	Phase	Sound pressure dB(A) @ 10 m.	Prix Liste (€HT)
		air 24°/eau 26°		air 15°/eau 26°*							
		kW	COP	kW	COP						
UTHP-9-HX-R32	UltraTemp-HX 9	10	6,68	8,43	5,48	4,3	16	230-240	1~	29	on demand
UTHP-12-HX-R32	UltraTemp-HX 12	12,23	7,03	9,29	5,43	5,3	16	230-240	1~	29	on demand
UTHP-15-HX-R32	UltraTemp-HX 15	15,27	6,53	12,25	5,35	6,6	20	230-240	1~	30	on demand
UTHP-17-HX-R32	UltraTemp-HX 17	17,26	6,64	14,51	5,4	7,5	25	230-240	1~	30	on demand

* conforme à la norme NF414

DIMENSIONS

Part Number	Model	A (mm)	B (mm)	C (mm)	D (mm)	E (mm)	F (mm)	G (mm)	H (mm)	Net Weight (kg)
UTHP-9-HX-R32	UltraTemp-HX 9									56
UTHP-12-HX-R32	UltraTemp-HX 12									61
UTHP-15-HX-R32	UltraTemp-HX 15									75
UTHP-17-HX-R32	UltraTemp-HX 17	757	1125	181	750	446	490	86,5	455	96

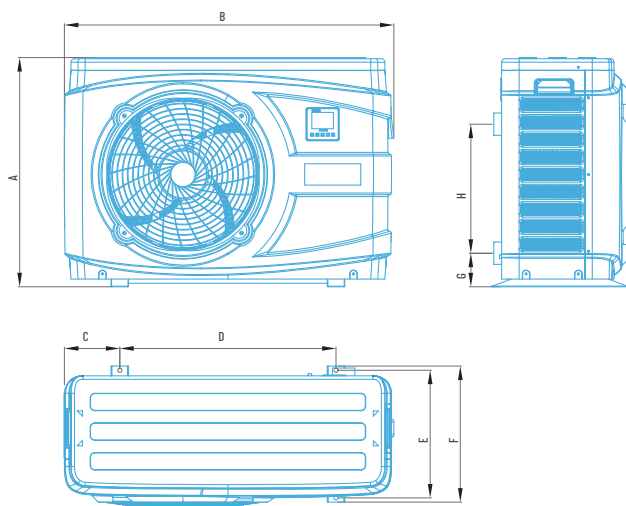

PACKAGING

Part Number	Model	Palet LxBxH	Pce /Palet	Gross Weight (kg)
UTHP-9-HX-R32	UltraTemp-HX 9	970x422x790	1	63
UTHP-12-HX-R32	UltraTemp-HX 12	970x422x790	1	68
UTHP-15-HX-R32	UltraTemp-HX 15	1150x500x890	1	86
UTHP-17-HX-R32	UltraTemp-HX 17	1150x500x890	1	108

MASTERTEMP®



The fastest way to heat your swimming pool, only when you need it.

FEATURES

- ◆ Compact Design for easy installation or retrofit in smaller spaces.
- ◆ Up to 82% thermal efficiency.
- ◆ Quick heat up due to the highly efficient air and gas pre-mixed system.
- ◆ Super-quiet operation.
- ◆ Easy-to-view, rotating digital display.
- ◆ Hot surface ignition makes the MasterTemp® as easy to operate as your home heating system.
- ◆ Tough, rustproof composite exterior handles the heat and weathers the elements.
- ◆ Diagnostic lights for easy troubleshooting.
- ◆ Copper nickel heat exchanger (HD versions only) to resist salt/chemical and phosphate/calcium corrosion.
- ◆ Build in safeties: Gas/air flow control, gas/air proportions, constant blue flame for ignition, high limit switches, water pressure switch, chemical backup valve, stack flue sensor against overheating.
- ◆ Natural gas and propane compliant in following countries : France, UK, Belgium, Austria, Switzerland, Czech Republic, Spain, Italy, Portugal, Lithuania, Ireland, Slovenia, Slovakia, Germany, Roumania, Greece.
- ◆ Compliant with Gaz equipment regulation of 21st of April 2018.



TECHNICAL FEATURES

Part Number	Model	Gas		Firing Rate				Weight (kg)	List Price (€ VAT excl.)
		Type	Min consumption	Gross		Net			
				BTU / H	kW / H	BTU / H	kW / H		
461078	MasterTemp 125, Nat.	Natural	4,12m ³ /h	125000	37	113000	33	45	2495
461079	MasterTemp 125, Pro.	Propane	4,12m ³ /h	125000	37	113000	33	45	2486
460902	MasterTemp 125HD, Nat.	Natural	4,12m ³ /h	125000	37	113000	33	45	2606
460903	MasterTemp 125HD, Pro.	Propane	4,12m ³ /h	125000	37	113000	33	45	2606
461082	MasterTemp 200HD, Nat.	Natural	6,6m ³ /h	200000	59	180000	53	58	3429
461083	MasterTemp 200HD, Pro.	Propane	6,6m ³ /h	200000	59	180000	53	58	3414
461086	MasterTemp 300HD, Nat.	Natural	9,9m ³ /h	300000	88	270000	79	62	3490
461087	MasterTemp 300HD, Pro.	Propane	9,9m ³ /h	300000	88	270000	79	62	3561
461090	MasterTemp 400HD, Nat.	Natural	13,2m ³ /h	400000	117	340000	100	62	3648
461091	MasterTemp 400HD, Pro.	Propane	13,2m ³ /h	400000	117	340000	100	62	3648

MASTERTEMP 125 / 125 HD

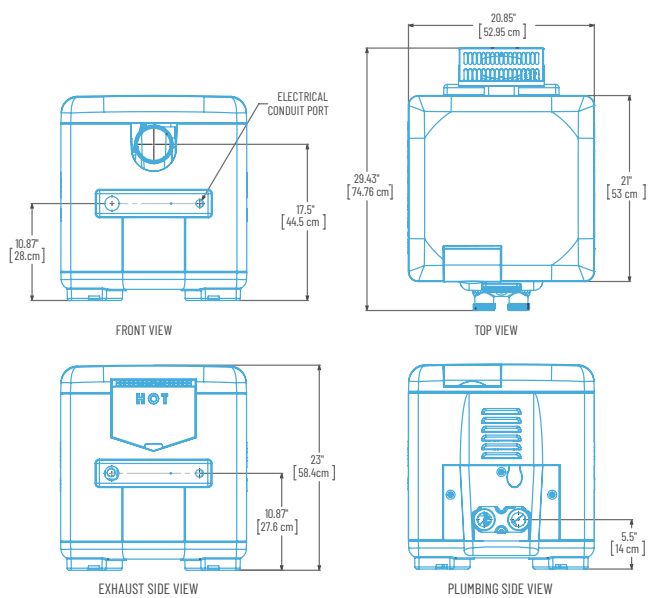

MASTERTEMP 200HD / 300HD / 400HD

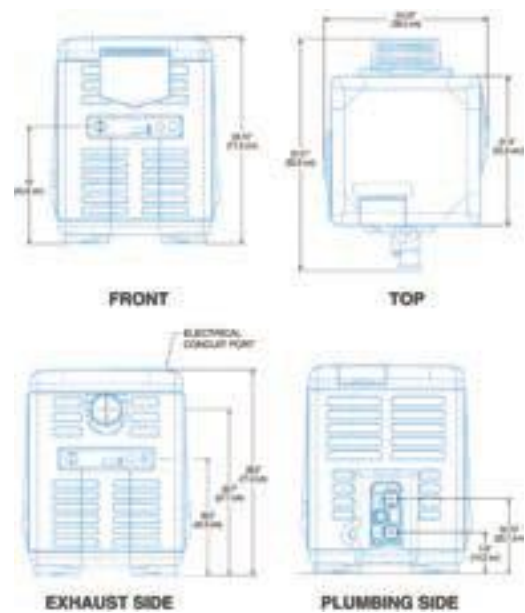



UNDER WATER LIGHTS

UNDER WATER LIGHTS

LIGHTS

INTELLIBRITE®-PAR56 WHITE/COLOR	94
INTELLIBRITE®-E POOL	95
INTELLIBRITE®-E SPA	96
MICROBRITE®	97

NICHES

INTELLIBRITE-E® NICHE	98
-----------------------------	----

ACCESSORIES

FOR UNDER WATER LIGHTS	99
------------------------------	----

CONTROLLERS

CONTROLBRITE™ LIGHTS CONTROLLER	100
INTELLIBRITE® CONTROLLER	101



INTELLIBRITE®-PAR56

PAR56 replacement light.

FEATURES

- ◆ Available in white and color-changing.
- ◆ Power LED technology.
- ◆ Fit in all pools equipped with PAR56 niches.
- ◆ Can be used for both new pool and as replacement of conventional incandescent bulbs.
- ◆ Automatic intensity reduction, cooling fins and Graphite heat dissipator protect light from overheating for extended product life.
- ◆ Compatible with any IntelliBrite compatible controller.
- ◆ Synchronizes with the Magicstream® Laminars as well as any other IntelliBrite compatible lights.



TECHNICAL FEATURES & PRICE

Model	Description	Type	Voltage (V)	Watts (W)	Lumen Output (lm)	List Price (€ VAT excl.)
INTB-P56W	IntelliBrite-PAR56 for standard PAR56 niche	White	12	44	4400	189
INTB-P56C	IntelliBrite-PAR56 for standard PAR56 niche	Colour	12	40	1150	290



DIMENSIONS

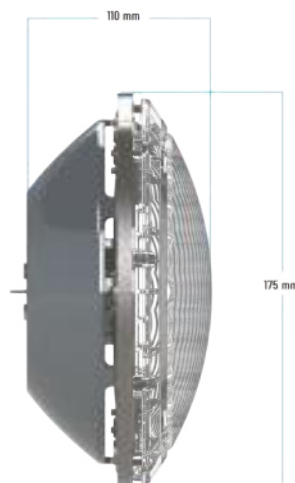



INTELLIBRITE®-E POOL

High performance and extra flat LED light for an easy wall fitting or IntelliBrite-E niche installation.



FEATURES

- ◆ Available in white and color-changing.
- ◆ Power- and Mid-power LED technology.
- ◆ Extra flat design for perfect integration in the pool design.
- ◆ Graphite heat dissipator for extended product life.
- ◆ Unpluggable for easy maintenance.
- ◆ Two mounting ways, directly in wall fittings or with the IntelliBrite-E Niche (see p. 99).
- ◆ Compatible with any IntelliBrite controller.
- ◆ Synchronizes with the Magicstream®Laminars as well as any other IntelliBrite compatible lights.
- ◆ Provided with 3m cable.

TECHNICAL FEATURES & PRICE

Part Number	Description	Type	Voltage (V)	Watts (W)	Lumen Output (lm)	List Price (€ VAT excl.)
INTB-EPWT	IntelliBrite®-E POOL WHITE 44W for wall fitting	White	12	44	4400	203
INTB-EPCT	IntelliBrite®-E POOL COLOR 40W for wall fitting	Color	12	40	1150	286
INTB-EPWN	IntelliBrite®-E POOL WHITE 44W for IntelliBrite-E Niche	White	12	44	4400	203
INTB-EPCN	IntelliBrite®-E POOL COLOR 40W for IntelliBrite-E Niche	Color	12	40	1150	286

White ABS face ring included / Other colors available (see p. 99)



DIMENSIONS

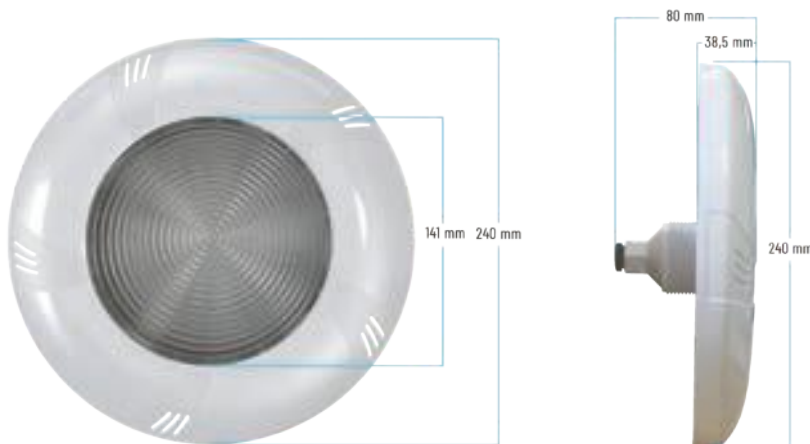

INTELLIBRITE®-E SPA

High performance and super compact LED light for an easy wall fitting or IntelliBrite-E niche installation.



FEATURES

- ◆ Power LED technology.
- ◆ Extra compact design for perfect integration in pool stairs, thalaso or kids' corner.
- ◆ Graphite heat dissipator for extended product life.
- ◆ Unpluggable for easy maintenance.
- ◆ Two mounting ways, directly in wall fittings or with the IntelliBrite-E Niche (see p. 99).
- ◆ Compatible with any IntelliBrite controller.
- ◆ Synchronizes with the Magicstream®Laminars as well as any other IntelliBrite compatible lights.
- ◆ Provided with 3m cable.



TECHNICAL FEATURES & PRICE

Part Number	Description	Type	Voltage (V)	Watts (W)	Lumen Output (lm)	List Price (€ VAT excl.)
INTB-ESW	IntelliBrite®-E SPA WHITE 14W, 1½" wall fitting or IntelliBrite-E Niche	White	12	14	866	131
INTB-ESC	IntelliBrite®-E SPA COLOR 12W, 1½" wall fitting or IntelliBrite-E Niche	Color	12	12	411	241

Face ring not included (see p. 99)

DIMENSIONS

Face ring for IntelliBrite-E niche mounting

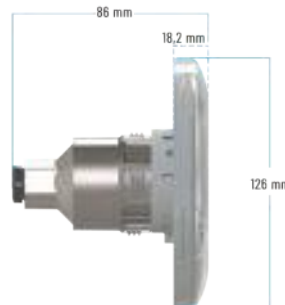
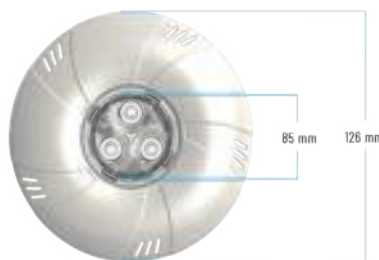

Face ring for wall fitting mounting

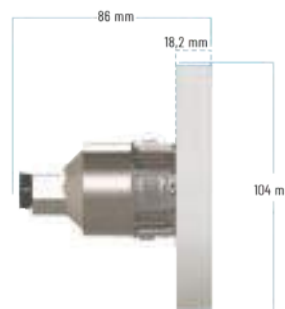

MICROBRITE®

The most compact, brilliant pool and spa wall-fitting LED light available!

FEATURES

- ◆ The industry's smallest, ultra-bright LED light.
- ◆ No niche required; fits in any standard 1.5-in. pool wall fitting.
- ◆ Installs horizontally or vertically in as shallow as 10 cm.
- ◆ Compatible with Pentair automation systems and the IntelliBrite® Controller.
- ◆ Fit where others don't, such as in narrow walls and tight spaces.
- ◆ Add visual excitement along steps, sun shelves and in swimouts.



SPÉCIFICITÉS TECHNIQUES ET PRIX

Part Number	Description	Type	Voltage (V)	Watts (W)	Lumen Output (lm)	PIP Points	List Price (€ VAT excl.)
620424-EU	MicroBrite®, Color, 3-meter Cord	Color	12	12	700	200	328
620428-EU	MicroBrite®, White, 3-meter Cord	White	12	12	1200	150	238
620457-EU	MicroBrite®, Warm White, 3-meter Cord	Warm White	12	12	1200	150	238



INTELLIBRITE-E® NICHE

Easy to install universal niche.



FEATURES

- ◆ Universal niche for any kind of pool structure and coating
- ◆ Easy lock-on system with only ¼ of turn.
- ◆ One niche for both IntelliBrite-E Pool & Spa.
- ◆ Makes IntelliBrite-E light installation & maintenance more simple, ecological and economic.
- ◆ Compact design.

TECHNICAL FEATURES & PRICE

Part Number	Description	Type	Voltage (V)	Watts (W)	List Price (€ VAT excl.)
INTB-NICHE	IntelliBrite-E universal niche				60.8
KIT-INTB-W1	Niche Pack IntelliBrite-E Pool White - White ABS face ring	White	12	44	259
KIT-INTB-C1	Niche Pack IntelliBrite-E Pool COLOR - White ABS face ring	Color	12	40	340
KIT-INTB-W2	Niche Pack IntelliBrite-E Spa WHITE - White ABS face ring	White	12	14	201
KIT-INTB-C2	Niche Pack IntelliBrite-E Spa COLOR - White ABS face ring	Color	12	12	311

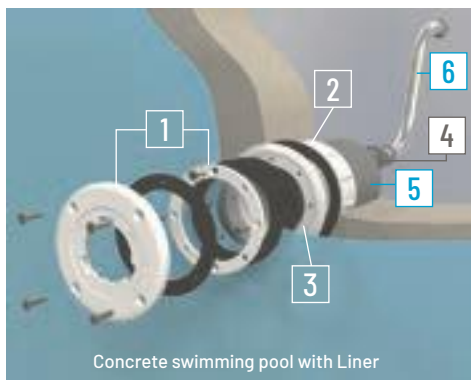

- Included
- 1 Sealing set
 - 2 Locking nut
 - 3 Niche
 - 4 Flexible cable adaptor
- Not incl.
- 5 125 mm PVC pipe
 - 6 Flexible cable (H-NICHE-CON)

DIMENSIONS

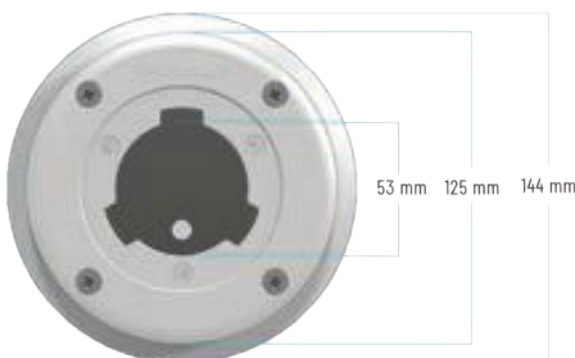

UNDER WATER LIGHTS ACCESSORIES

Part Number	Description		List Price (€ VAT excl.)
H-NICHE-CON	1.5m flexible cable with 3/4" thread		15.26
G-NICHE-SEAL	Seal grommit		5.98
G-DECKBOX-1	Deck box for lights		19.61
INTB-0100	Safety isolating transformer 12V/13V/14V - 1 x 100W (VA)		145
INTB-0300	Safety isolating transformer 12V/13V/14V - 1 x 300W (VA)		186
G-WALL-LLO	Wall fitting 2", 300mm length		11.05
G-WALL-LSH	Wall fitting 2", 50mm length		10.23
G-VAC-LIN	Wall fitting adaptor ring 1,5" (int.) to 2" (ext.) with sealing set		12.51

FACE RINGS

Part Number	Colour	Description	List Price (€ VAT excl.)
INTB-2060	White	Intellibrite-E Pool face rings 	9.97
INTB-2061	Almond		
INTB-2062	Silver grey		
INTB-2063	Anthracite		
INTB-2064	Stainless Steel		
INTB-2080	White	Intellibrite-E Spa face ring for niche Adaptator and tool provided. 	8.15
INTB-2081 ⁽¹⁾	Almond		
INTB-2082 ⁽¹⁾	Silver grey		
INTB-2083 ⁽¹⁾	Anthracite		
INTB-2084 ⁽¹⁾	Stainless Steel		
INTB-2090	White	Intellibrite-E Spa face rings for wall fitting 	8.15
INTB-2091	Almond		
INTB-2092	Silver grey		
INTB-2093	Anthracite		
INTB-2094	Stainless Steel		

 ⁽¹⁾ Non applicable for polyester pool,
Please contact your Pentair representative.

INTELLIBRITE® CONTROLLER



Wall mounted IntelliBrite-E lights and Magic Stream Laminars controller.

FEATURES

- ◆ Waterproof Outdoor LED color light controller.
- ◆ Selection of 5 fixed colors and 7 light shows.
- ◆ Convenient hold and recall functions for your favorite colour.
- ◆ Back-lighted power button.

Part Number	Description	List Price (€ VAT excl.)
620139	IntelliBrite wall mounted controller 220V AC CE	420

Light shows



SAm Mode



Party Mode

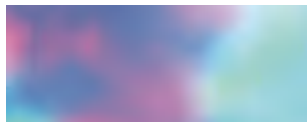

Romance Mode



California Sunset Mode



CONTROLBRITE™



IntelliBrite-E lights and Magic Stream Laminar controller with remote control.

FEATURES

- ◆ Compact module, easy to install on a DIN rail in existing electric panel.
- ◆ Remote Control with up to 30m range.
- ◆ Selection of 5 fixed colors and 7 light shows.
- ◆ Convenient hold and recall functions for your favorite colour.
- ◆ Fixed color or light show numbers appears on the display.

Part Number	Description	List Price (€ VAT excl.)
CTRB-1010	ControlBrite™ Lights Controller w/ remote control	221



American Mode



Caribbean Mode



Royal Mode



WATER FEATURES

WATER FEATURES

MAGICSTREAM™ LAMINAR.....104

MAGICSTREAM™ DECK JET I & II.....105

WATER FALLS

MAGICFALLS™ WATER FALLS.....106



MAGICSTREAM™ LAMINAR



Brilliant colors, totally clear and uniform water arcs. Magicstream™ Laminar uses your pool water to create colored animation originating from your pool deck or surrounding landscape.

FEATURES

- ◆ Water arcs can reach up to 2 meters high and project out 2,5 meters into your pool.
- ◆ Installation is made flush to your deck or other surface: no unsightly or unsafe edge.
- ◆ Nighttime color effects: ability to hold on a steady color or scroll through a range of colours.
- ◆ Water streams easily adjusted in two ways; vertically and left and right direction.
- ◆ MagicStream Laminar comes fully assembled and ready to install. To create spectacular nighttime effects, a LED light engine is included. Simply add plumbing and 12V pool transformer to provide power.
- ◆ ControlBrite and IntelliBrite Controller compatible.
- ◆ Synchronisation with IntelliBrite-E lights.

TECHNICAL FEATURES & PRICE

Part Number	Description	Performance (M ³ /h)	Inlet Pressure (bar)	Height of jet (m)	List Price (€ VAT excl.)
580001T-EU	Laminar LED 12V TAN	1,4	0,17	1,5	1154
		1,7	0,24	1,8	
		1,9	0,31	2,1	

PACKAGING

Part Number	Light Source (W)	Length (cm)	Width (cm)	Height (cm)	Pce/Palet
580001T-EU	16	44	44	57	12

ACCESSORIES

Part Number	Description	List Price (€ VAT excl.)
CTRB-1010	ControlBrite™ Lights Controller (p.96)	221
620139	IntelliBrite® Controller (p.96)	420

DIMENSIONS

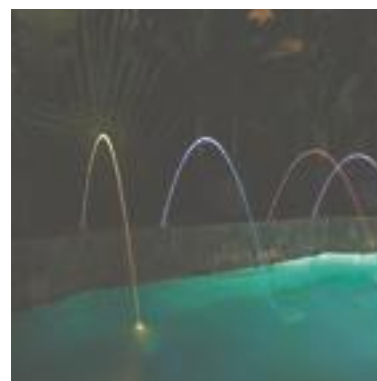

MAGICSTREAM™ DECK JET I & II



Magicstream™ jets create a graceful arc of water that seems to appear from your pool deck. Economic and easy to use, they don't need any other equipment to work properly.

TECHNICAL FEATURES & PRICE

Part Number	Description	Warranty (years)	List Price (€ VAT excl.)
580000-EU	MagicStream - Deck Jet I	2	174
580003-EU	MagicStream - Deck Jet II	2	97,18



MAGICSTREAM® DECK JET I

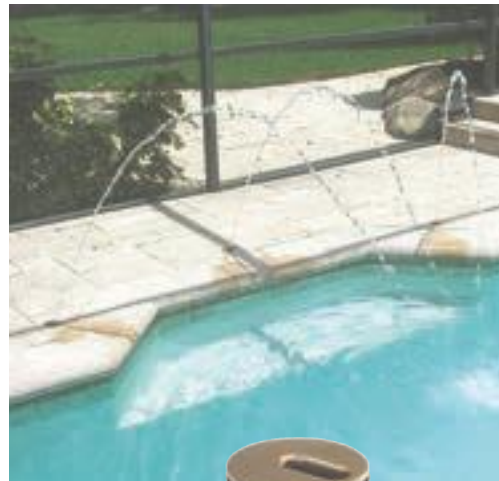

MAGICSTREAM® DECK JET II

MAGICFALLS™ WATER FALLS



Transform your swimming pool in a water fall with the Magicfalls™. Easy to install, no additional equipment is needed.

FEATURES

- ◆ Choose from a variety of effects - sheet or rainfall.
- ◆ For every 300 mm width of waterfall, the minimum waterflow is 2,3 m³/h, the recommended flow per 300 mm is 3,5 m³/h.
- ◆ All connection are 1,5" (ABS), supplied with a 50 mm slip fit adaptor (PVC).

TECHNICAL FEATURES & PRICE

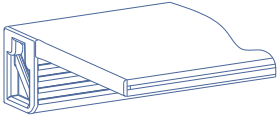
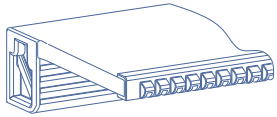
	Part Number	Description	Depth (mm)	Color	List Price (€ VAT excl.)
SHEET EFFECT					
	581201FSW-EU	MagicFalls SHEET 300mm (1')	152,40	White	343
	581218FSW-EU	MagicFalls SHEET 450mm (18")			382
	581202FSW-EU	MagicFalls SHEET 600mm (2')			431
	581203FSW-EU	MagicFalls SHEET 900mm (3')			528
RAINFALL EFFECT					
	581201FRW-EU	MagicFalls RAINFALL 300mm (1')	152,40	White	446
	581218FRW-EU	MagicFalls RAINFALL 450mm (18")			483
	581202FRW-EU	MagicFalls RAINFALL 600mm (2')			536
	581203FRW-EU	MagicFalls RAINFALL 900mm (3')			631

RAINFALL-EFFECT

SHEET-EFFECT



DIMENSIONS

Part Number	A (mm)	B (mm)
581201FSW-EU	328,7	164,3
581218FSW-EU	481,0	240,5
581202FSW-EU	633,5	316,7
581203FSW-EU	938,3	469,1
581201FRW-EU	328,7	164,3
581218FRW-EU	481,0	240,5
581202FRW-EU	633,5	316,7
581203FRW-EU	938,3	469,1

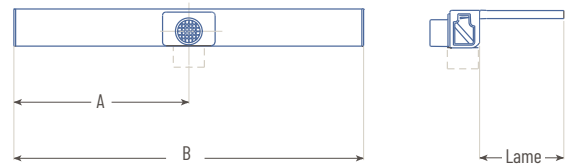

WHITE GOODS

STARGUARD® MAIN DRAIN 110

DECKBOX..... 110

VACUUM PLATE..... 110

WALL FITTINGS..... 111

EYEBALL INLET 111



STARGUARD® MAIN DRAIN



Anti-entrapment and compliant main drain.

FEATURES

- ◆ ANSI/ASME A112.19.8-2007 and "Virginia Graeme Baker Pool and Spa Safety Act" (VGBA) standards compliant.
- ◆ New improved 8" version : has an industry leading 99 cm² of open area for water flow.
- ◆ Allow flow rate up to 16 m³/h (72 gpm) at 0,45 m/s (1-1/2 ft/sec).

Part Number	Description	List Price (€ VAT excl.)
500150	StarGuard - Special elevated anti-entrapment 8" main drain, VGBA compliant	109



DECKBOX

Part Number	Description	List Price (€ VAT excl.)
G-DECKBOX-1	Deckbox	19.61



VACUUM PLATE

Part Number	Description	List Price (€ VAT excl.)
G-SKI-VAC	Vacuum Plate	6.73



WALL FITTINGS

Part Number	Description	Taille (mm)	List Price (€ VAT excl.)
G-WALL-LLO	Wall fitting liner	300	11.05
G-WALL-LSH	Wall fitting liner	250	10.23



EYEBALL INLET

Part Number	Description	List Price (€ VAT excl.)
G-INLET-LIN	Eyeball inlet for liner pool	26.45





OTHER

OTHER

FILTER VALVES.....	114
FILTER CARTRIDGES	115
PUMP UNION KITS.....	116
PUMP REPLACEMENT BASKETS.....	116
PUMP MOTORS.....	117



FILTER VALVES

TOP MOUNT (TM)



Part Number	Filter	Sizes	Media	Nb Ways	Port Thread	Color
RE272026ND	Azur™	15"-19"-22"	Sand	6	1½" BSP	Black
	Tagelus®	Tagelus® 40 & 60	Sand	6	1½" BSP	Black
RE272029ND	Tagelus®	Tagelus® 100	Sand	6	2" BSP	Black
	Cristal-Flo™	TM-760	Sand	6	2" BSP	Black
R14965TM10	Cristal-Flo™	T-380 to T-600	Sand	6	1½" BSP	Black

SIDE MOUNT (SM)



RE261069B	Azur™	All side mount	Sand	6	1½" BSP	Black
RE261069B	Cristal-Flo™	SM-430 à SM-600	Sand	6	1½" BSP	Black
RE261070ND	Triton®	Triton® 40 & 60	Sand	6	1½" BSP	Black
RE261071ND	Triton®	Triton® 100 & 140	Sand	6	2" BSP	Black
RE261071ND	QUAD®	H-18-8592/4	D.E.	2	2" BSP	Black
RE261071ND	Cristal-Flo™	SM-760	Sand	6	2" BSP	Black
PROV-1010 ⁽¹⁾	Triton®	Tous Triton® + Pro Valve	Sand	6	2" BSP	Black
RPIF006	Poseidon™	Poseidon™ 500 - 600	Sand	6	1½" BSP	Black
RPIF007	Poseidon™	Poseidon™ 800	Sand	6	2" BSP	Black

O-ring seal to filter is included with all valves

⁽¹⁾ Sea water version (4,5%) available on demande. Please ask to your Pentair representative.

FILTER CARTRIDGES

Part Number	Nb Pces	Description	Application
QUAD D.E.®			
H-17-8654	1	Cartridge	H-18-8592/4
CLEAN & CLEAR™			
H-RAF173213	1	Cartridge	H-16-0314
H-RAF173214	1	Cartridge	H-16-0315
H-RAF173215	1	Cartridge	H-16-0316
H-RAF173216	1	Cartridge	H-16-0317
H-RAF173217	1	Cartridge	H-16-0318
CLEAN & CLEAR™ PLUS			
H-RAF173572	1	Cartridge	H-16-0310
H-RAF173573	1	Cartridge	H-16-0340
H-RAF173576	1	Cartridge	H-16-0301
H-RAF173578	1	Cartridge	H-16-0332
POSI-CLEAR™			
25230-0075S	1	Cartridge	PXC75
25230-0095S	1	Cartridge	PXC95
25230-0125S	1	Cartridge	PXC125
25230-0150S	1	Cartridge	PXC150
POSI-CLEAR™ RP			
H-RAF173215	1	Cartridge	PXC-RP100
H-RAF173216	1	Cartridge	PXC-RP150
H-RAF173217	1	Cartridge	PXC-RP200
SYSTEM 2™			
27002-0100S	1	Cartridge	PLM100
27002-0150S	1	Cartridge	PLM150
27002-0175S	1	Cartridge	PLM175
27002-0200S	1	Cartridge	PLM200

PUMP UNION KITS

Part Number	Nb Pces	Description	Application	Connections for PVC tube Ø
R505426	2	Half Union : 50 mm slip fit	Swimmey™	50 mm
R505427	2	Half Union : 1 1/2" slip fit	Swimmey™	1 1/2"
R0018	2	Half Union : 50 mm slip fit	FreeFlo™	50 mm
R0019	2	Half Union : 1 1/2" Int. 2" slip fit	FreeFlo™	1 1/2" / 2"
R170450	2	Half Union : 50 mm slip fit	SuperFlo®	50 mm
170451	2	Half Union : 1 1/2" Int. 2" Ext. slip fit	SuperFlo®	1 1/2" / 2"
R170498	2	Union : 2" BSP à 50/63 mm slip fit	UltraFlow® WhisperFlo® IntelliFlo® WFL / UFL	50 / 63 mm
PKG 188	2	Half Union : 2" slip fit	5MPR™ (SW) 5P6R™	2" (60,4 mm)
RPKG188W	2	Half Union : 63 mm slip fit	5MPR™ (SW) 5P6R™ IntelliFlo® SW5P6R™ VSD	63 mm
R170396	2	Union : 1 1/2" BSP à 50 mm slip fit	(S) 5P2R™	50 mm
R411000	2	Union Kit : 75/90 mm	5PXF™ IntelliFlo® 5PXF™ VSD	70 / 90 mm
R170498	2	Union : 2" BSP à 50/63 mm slip fit	Ultra-Glas™ WhisperPro™	50 / 63 mm
R170450	2	Half Union : 50 mm slip fit	SuperMax®	50 mm
170451	2	Half Union : 1 1/2" Int. 2" Ext. slip fit	SuperMax®	1 1/2" / 2"



PUMP REPLACEMENT BASKETS

Part Number	Application
R302310	Swimmey™
R355667	FreeFlo™ SuperMax®
R39303500	UltraFlow® Ultra-Glas®
R070387	WhisperFlo® IntelliFlo® WhisperFlo® VSD/VF WhisperPro®
R400007	5PXF™ / 5PXF™ VSD
RC10833P	5P2R™ / S5P2R™ SERIES 5BR™
RC858P	5MPR™ 5P6R™ / SW5P6R™ SERIES IntelliFlo® SW5P6R™ VSD
R0007	FreeFlo™

PUMP MOTORS

Part Number	kW	HP	Phase	Whisperflo®	UltraFlow® Plus	SuperFlo®	5PXF™	SW5P6R™	5P6R™	WhisperPro® S5P5R™	Ultra-Glas™ S5P3R™	5P2R™	S5P2R™	SuperMax® S5P1R™	5BR™
RP051	0,37	½	1~			X									
RP071	0,55	¾	1~	X	X	X									
RP073	0,55	¾	3~	X	X	X									
RP101	0,75	1	1~	X	X	X									
RP103	0,75	1	3~	X	X	X									
RP151	1,1	1,5	1~	X	X	X									
RP153	1,1	1,5	3~	X	X	X									
RP201	1,5	2	1~	X	X	X									
RP203	1,5	2	3~	X	X	X									
RP301	2,2	3	1~	X		X									
RP303	2,2	3	3~	X		X									
RA-SH1	2,2	3	1~		X										
RA-SH3E3	2,2	3	3~		X										
RA-C1	0,37	½	1~									X			X
RA-C3	0,37	½	3~									X			X
RA-D1	0,55	¾	1~						X			X			X
RA-D3	0,55	¾	3~						X			X			X
RA-E1	0,75	1	1~						X			X			X
RA-E3E3	0,75	1	3~						X			X			X
RA-F1	1,1	1,5	1~						X			X			X
RA-F3E3	1,1	1,5	3~						X			X			X
RA-G1	1,5	2	1~						X						
RA-G3E3	1,5	2	3~						X						
RA-H1	2,2	3	1~				X		X						
RA-H3E3	2,2	3	3~				X		X						
RA-J1	3,0	4	1~				X								
RA-J3E3	3,0	4	3~				X								
RA-SC1	0,37	½	1~										X	X	
RA-SC3	0,37	½	3~										X		
RA-SD1	0,55	¾	1~					X		X	X		X	X	
RA-SD3	0,55	¾	3~					X		X	X		X	X	
RA-SE1	0,75	1	1~					X		X	X		X	X	
RA-SE3E3	0,75	1	3~					X		X	X		X	X	
RA-SF1	1,1	1,5	1~					X		X	X		X	X	
RA-SF3E3	1,1	1,5	3~					X		X	X		X	X	
RA-SG1	1,5	2	1~					X		X	X			X	
RA-SG3E3	1,5	2	3~					X		X	X			X	
RA-SH1	2,2	3	1~					X		X	X			X	
RA-SH3E3	2,2	3	3~					X		X	X			X	

GENERAL CONDITIONS OF SALE EUROPE

ARTICLE 1: INCEPTION OF THE AGREEMENT

- The company "PENTAIR INTERNATIONAL SARL", hereafter referred to as "the Seller", shall only be bound by the remittance of an order confirmation, drawn up on its own letterhead and containing the General Conditions stated hereafter.
- The contractual relations between the Seller and the Buyer shall be governed exclusively by the present General Conditions of Sale. By approving the order confirmation the Purchaser explicitly waives reference to its own conditions.
- Other conditions may not be held against the Seller except further to its own explicit written consent.

ARTICLE 2: MINIMUM ORDER

If the buyer places a "product" order for an amount less than € 200, then the Buyer will be assessed a € 30 processing fee.

ARTICLE 3: OFFERS – ESTIMATES

- Unless explicitly agreed otherwise, all offers made by the Seller shall be without obligation in all respects.
- Any information provided by the Seller in its catalogues, prospectuses, price lists and/or any other document is given merely as an indication.
- The manufacturer shall be entitled to make changes to products without prior warning, insofar as their properties are not essentially modified by such changes.
- An Agreement shall only be considered to have been entered into if and provided that an order has been confirmed in writing by the Seller.

Any arrangements with agents, representatives or other intermediaries shall be binding upon the Seller only if confirmed in writing by the Seller.

ARTICLE 4: DELIVERY

Delivery dates given by the Seller shall only be considered to be indications and shall not in any event be binding. Unless explicitly otherwise agreed upon, the Buyer may therefore not unilaterally withdraw an order because of a failure to meet the delivery date; nor may such circumstance give rise to any compensation for damages in its behalf.

All price lists, offers and order confirmations shall be considered to apply to delivery "ex works Herentals (Belgium)", including packaging.

In all circumstances the risk for the goods shall transfer to the Purchaser at the time of delivery, being the moment in time when the goods are placed at the Buyer's disposal in the Seller's warehouse.

The Seller shall always be entitled to make partial deliveries.

ARTICLE 5: PRICES - TAXES

Unless explicitly agreed upon otherwise, all Seller's prices shall be "ex works Herentals (Belgium)", including packaging.

Prices shall be quoted net, exclusive of taxes, dues, Customs duties and any other duty that may be levied on the goods.

ARTICLE 6: LETTER OF CREDIT

In the event that any sales agreements should take place involving an L/C, the procedure of Pentair Water Belgium will be adapted as appropriate. The set procedure can be requested from our administrative department at any time.

ARTICLE 7: PAYMENT – RETENTION OF OWNERSHIP

All our invoices are due and payable immediately at the address stated on the invoice, unless otherwise agreed upon between the Parties in binding documentation or if a payment date is stated on the invoice.

In the event of failure to make immediate payment or payment by a stated date, a contractual penalty of 1.5% per month shall apply to the amount invoiced without prejudice to the exercise of any further legal rights, such interest to be calculated from the date of issuance of the invoice or from the stated due date. Any started month shall be considered to be a full month.

In addition, the invoice amount shall, automatically and without further notice, be increased, by way of a flat fee and irrevocable clause by 15% with a minimum amount of € 62.00,- representing compensation for collection costs in respect to the claim (such as personnel and administration costs, case management and follow-up, effects on financial management, etc.) all the above in application of Arts. 1147 B.W. [Belgian Civil Code] and 1152 B.W.

The said compensation shall be due in addition to late payment interest, collectible procedural costs and any potential compensation for property damages and loss of earnings.

The Parties therefore hereby explicitly agree that the said compensation shall be of a blanket nature and that it may, in deviation from Art. 1231 B.W., not be changed even in the event of an only partial default.

Cheques and bills of exchange shall be considered to constitute means of payment only after their collection. Any potential costs in connection therewith shall be for the account of the Buyer or Customer.

The drawing and/or acceptance of bills of exchange or other negotiable instruments shall not constitute a renewal of debt or a deviation from the General Conditions. Any potential costs in connection with the acceptance of bills of exchange shall be for the account of the Buyer or Customer.

In the event of non-payment of an invoice by the Buyer the Seller shall be entitled to suspend performance of its remaining contractual obligations.

Any goods not completely paid for shall remain in the Seller's full ownership in deviation from Art. 1583 of the Belgian Civil Code: any advance payments shall then be considered to be compensation for costs and loss of earnings.

In the event of default, the Seller shall always be entitled to recover the goods from the Buyer. In such cases, the Seller shall beforehand send the Buyer a recorded delivery letter announcing the default and granting the Buyer a payment term of seven calendar days.

ARTICLE 8: COMPLAINTS

Any complaints in connection with the delivery of goods and/or provision of services or the performance of work must be submitted at the time of delivery and confirmed by means of a substantiated recorded delivery letter within 15 days following the date of delivery or performance. Such complaints shall not suspend the Buyer's payment obligations. All correspondence shall be in Dutch, French, German or English. Any remarks and restrictions in connection with the invoice and/or the general conditions stated therein shall be communicated to us in a substantiated recorded delivery letter within eight days following the date of invoice: as concerns disputes regulations, this deadline is of 30 days.

ARTICLE 9 : CLAIM PROCESS AND PROCEDURE FOR RETURN OF GOODS

Summary of Pentair Claim Process in 4 steps:

- CLAIM:** Distributor contacts Pentair Customer Service and provides completed Complaints Registration Form which includes:
 - Information about the failed product such as the part number(s) and serial number(s)
 - Description of the complaint/failure
 - Pictures
- RECEIPT:** Once the Complaints Registration Form is received, Pentair Customer Service will register an incident. Each registered incident will get a unique IR (Issue Resolution) number.
- INVESTIGATION:** The Product Quality Incident will then be reviewed by Pentair's Quality Department following the "Limited Warranty Conditions" in the 2017-2018 Pentair Aquatic Systems Catalog.

4. CONCLUSION: After the investigation is completed, Pentair will inform the distributor accordingly. Distributors are not allowed to return goods to Pentair on their own initiative. Any return shipments without RMA-number and/or not organized by Pentair will be refused.

Pentair will evaluate the request for return and send a written authorization number (RMA) to the distributor if the return is required. This authorization does not imply any liability, whether direct or indirect, apparent or hidden, of Pentair and does not suspend in any event the payment owed by the distributor at the date they are due.

The distributor has to clearly mark the product and shipment documents with this RMA number. Once the distributor has confirmed the date on which the goods will be ready for pick-up and the volume and weight, Pentair will arrange the pick-up with their own forwarder. In case of requests of RMA for returns of new, non-defective material due to mistakes of Pentair or of the distributor the RMA will have to be requested within 15 days from the receipt of the product.

With "ex works" shipments (when the shipment has been picked up by the customer's forwarder), the complaints with regards to cost and risk of transport should be addressed to the forwarder.

In the case of new and non-defective products returned due to reduction of stock by any buyer, Pentair must be noticed in writing. No goods may be returned prior written consent by Pentair. Merchandise may be returned in new and unused condition for a full refund (less shipping) – special orders, custom and non-stocked items excluded, subject to a thirty percent (30%) restocking fee of the current prices. Returned items cannot show evidence of use or wear, dirt or other blemishes of any kind. Merchandise must be returned in its original packaging and should include all supplied materials, instructions, warranty cards, original accessories and hardware provided.

In case of requests of RMA for returns of defective material, the RMA can be requested at any time during the warranty period. This warranty is limited to the repair of the defective part(s) or to the replacement of products by a brand new product or reconditioned, at the sole choice of Pentair, without any further obligation whatsoever.

An RMA approved by Pentair, will only be compensated by means of a credit note or a replacement product.

ARTICLE 10: EXPLICIT RESOLUTION CLAUSE

In the event that the Buyer should remain in default of payment of its invoice and of reception of the goods, or if it should present signs of insolvency, such as court ordered bankruptcy or an extrajudicial creditors' agreement, liquidation, issuance of cheques without funds, protest, etc., the Seller shall be entitled to suspend performance of its obligation or unilaterally and automatically rescind the Agreement without notice by means of a recorded delivery letter without recourse to court action and without prejudice to its potential rights to damage compensation.

ARTICLE 11: FORCE MAJEURE

In the event of force majeure the Seller's delivery and other obligations shall be suspended. In that case, the Seller shall only be under the obligation to deliver on a best efforts basis. The following shall be considered to be force majeure: unexpected circumstances concerning persons and/or materials or equipment employed by the Seller in the performance of the Agreement so that timely performance on the Agreement should become either impossible or else difficult and/or disproportionately expensive to the Seller to the extent that it would not be able reasonably to assure such performance. Such circumstances shall include, by way of example but not of limitation, the following: governmental decisions, operating, circulation and/or transport disruptions, disruptions in the delivery of finished products, raw materials and/or intermediate products, strikes, lock-outs, obstacles due to third parties, technical complications unforeseen by either Party, etc.

ARTICLE 12: LEGAL LINGUISTIC VALIDITY

The legally valid form of the present Sales Conditions shall be the English language version.

WARRANTY INFORMATION

INTRODUCTION

This warranty supersedes all previous publications. Pentair Aquatic Systems ("Pentair") manufactures its products in accordance with industry standards of workmanship, using high quality materials and manufacturing processes. In the present document the name Pentair refers to the Pentair owned or controlled legal entities producing, distributing and selling Pentair in Europe.

All warranty periods will start from consumer invoice date if the product serial number is on the invoice and a written copy of the invoice is provided to Pentair. (If this invoice is not available, Pentair will apply the manufacturing date as starting date)

LIMITED WARRANTY: Unless a longer warranty period applies in accordance with the terms and conditions set forth in the "EXTENDED WARRANTY" section below, Pentair warrants its products to be free from defects in material and workmanship and to conform to the published or written specifications as they appear in this catalog for a period of ninety (90) days from the commencement date of the warranty period as set forth above.

EXTENDED WARRANTY: The following Pentair products shall have an extended warranty period as designated below (but not in addition to the LIMITED WARRANTY duration):

PRODUCT FAMILY	Extended warranty (service parts excluded)
Automation	2 years
Filters (incl. valves if applicable)	2 years Triton / Tagelus / Clean & Clear plus / Quad D.E: shell 10 years Azur / Cristal-flo: shell 5 years Poseidon: shell 5 years + 5 years
FILTER SYSTEMS	Check filter or pump warranty terms
Pumps	3 years
Heat pumps	2 years Titanium heat exchanger: 10 years
Heaters	
Cleaners	
Water features	
Lights	
Salt chlorinators	2 years
Dosing and Measurement equipment's	
valves	
sanitizers White goods	
Spare parts (service parts and consumables excluded)	
Maintenance accessories	LIMITED WARRANTY (90 days)
Cartridges and other consumables	

SERVICE PARTS have no extended warranty and only the LIMITED WARRANTY period (90 days) is applicable.

Service Parts are defined as the following: baskets, lids, fan covers, fans, O-rings, unions, gauges, batteries, mounting materials, igniters, measuring probes, fuses, mechanical seals.

If multiple problems occur, which are related to each other, the warranty period of the root cause will be taken as the warranty period for all components.

Exceptions that will result in denial of a warranty claim:

- Damage caused by careless handling, improper repackaging, disassembled products, shipping or any secondary shipping not realized by Pentair.
- Damage due to misapplication, misuse, abuse, lack of maintenance or failure to operate equipment as specified in the Pentair owner's manual.
- Damage caused by failure to install products as specified in the owner's manual.
- Damage due to unauthorized product modifications or failure to use Pentair original replacement parts or if the product is repaired or altered in any way by any persons, agents, or representatives that is not qualified*.
- Damage caused by negligence, or failure to properly maintain products as specified in the owner's manual.
- Damage caused by failure to maintain water chemistry in conformity with the standards of the swimming pool industry for any length of time.
- Damage caused by water freezing inside the product.
- Accidental damage, fire, acts of God, or other circumstances outside the control of Pentair.
- Damage caused by any flooding where the Pentair equipment is installed.

* Note: qualified persons or representatives are customers who have been trained by Pentair or licensed professionals who are registered in the PIP-program and attended the Pentair Academy about the relevant product.

Pentair's Warranty Obligations

Should a defect in workmanship and/or material in any item covered by this warranty become evident during the term of the warranty, then upon the consumer following the procedures set forth below. Pentair will, at its sole option, replace the defective component of the product. If it is not clear according to Pentair which component is causing the failure, Pentair can decide to replace the complete product.

After repair or replacement, the warranty period of the complete product will NOT be renewed.

Pentair is not, however, responsible under this warranty for any cost of shipping or transportation of the product or parts from the dealer to the Pentair location fulfilling the warranty obligations. Also, Pentair is not liable for any loss of time, inconvenience, incidental expenses such as telephone calls, labor or material charges incurred in connection with the repair, removal or replacement of the products, or any other incidental or consequential damages.

Reasonable vehicle trip and evaluation charges may be assessed by a Pentair service representative and charged to the product owner.

No Other Warranties

To the maximum extent permitted by applicable law, Pentair disclaims all other warranties,

either expressed or implied, including, but not limited to, implied warranties of merchantability and fitness for a particular purpose, with regard to the product(s), part(s) and/or any accompanying written materials.

Procedure for Obtaining Benefits of this Warranty

In order to obtain the benefits of this warranty, Pentair must be contacted by the customer as soon as possible after discovery of the product-related issue, but in no event later than the expiration date of the respective warranty periods provided herein. Upon receipt of this communication, Pentair will promptly start the investigation process to solve the complaint. After the investigation is completed, Pentair will inform the customer accordingly.

Customers are not allowed to return goods to Pentair on their own initiative. Any return shipments without RMA-number and/or not organized by Pentair will be refused. Pentair will evaluate the request for return and send a written authorization number (RMA) to the customer if the return is required. This authorization does not imply any liability, whether direct or indirect, apparent or hidden, of Pentair and does not suspend in any event the payment owed by the distributor at the date they are due. The customer has to clearly mark the product and shipment documents with this RMA number. Once the customer has confirmed the date on which the goods will be ready for pick-up and the volume and weight, Pentair will arrange the pick-up with their own forwarder.

Warranties or Representations by Others

No dealer or other person has any authority to make any different warranties or representations concerning Pentair or Pentair products. Accordingly, Pentair nor any of its entities are to be held responsible for any such warranties or representation.

Other rights

This warranty gives you specific legal rights as above described. In addition, consumer's rights are protected where applicable, following European Directives or, in absence of, National laws

LEGAL LINGUISTIC VALIDITY

The legally valid form of the present Pentair warranty terms and conditions shall be the English language version.

Customer Service Pisa, Italy (8.30 AM to 4.30 PM CET)

Phone number: +39 050 71 61 66 or +39 050 71 61 69

E-mail: orders.pooleu@pentair.com or poolemea@pentair.com



Pentair Partners Incentive Program



AQUATIC SYSTEMS EUROPE

CATALOG | 2020

Customer Service:

+39 050716166
+39 050716169
orders.pooleu@pentair.com

poolemea@pentair.com
www.pentairpooleurope.com

Copyright - Limited License: except as specifically permitted herein, no portion of the content on this document may be reproduced in any form or by any mean without the prior written permission of Pentair International SRL.

POOL CATALOG © 2019 Pentair International SRL. All Rights Reserved.

To obtain your catalogue
in your pocket.
Scan Me !

